

From clay. From concrete. From experience.

NELSKAMP

Twin trough gutter tile D 13



The twin trough gutter tile D 13.



The twin trough gutter tile D 13 gives a new format to this characteristic and classical tile shape. New buildings and modernisation projects are given a distinctive image with the easy-to-lay and economical D 13.

The D 13 in detail:

- Pressed roof tile according to DIN/EN 1304
- Twin head and side trough
- Waterproof, frost-resistant, breathable
- Regular roof pitch 30°
- Requirement per m² approx. 12.8 pcs



The Colours.



(115) natural red



(156) red engobed



(118) brown engobed

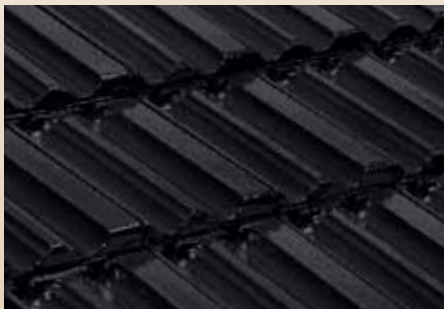

(120) black noble engobed
(matt black glazed)



(124) wine red engobed



(139) muscat noble engobed (glazed)



(141) old black engobed

Colour deviations: Our clay roof tiles are environment-friendly building materials. When using natural raw materials you may experience colour deviations. This is often the case with naturally red tiles since the fired colour is the sole result of natural raw materials with no added metal oxides to change the colour. Deviations are possible in the colours for reasons of printing methods.

Clay roof tile surfaces: Minor impairments to the surface are possible due to transport. This does not affect the quality of the tiles.

The program.

Moulded bricks for various functions meet the demand for homogeneous, architecturally demanding roofs. They are also an important safety factor. Moulded bricks and accessories reduce the amount of laying work and

facilitate calculations. You will find the complete program for every tile on our Internet website www.nelskamp.de.



Whole tile
Length: ~ 43.9 cm Covering length: ~ 36.5 cm ± 3 mm
Width: ~ 25.5 cm Covering width: ~ 21.5 cm
Weight: ~ 3.5 kg Requirement: ~ 12.8 pcs/m²



Half tile
Length: ~ 43.9 cm Covering length: ~ 36.5 cm ± 3 mm
Width: ~ 14.6 cm Covering width: ~ 10.7 cm
Weight: ~ 2.1 kg Requirement: individual



Double flap
Length: ~ 43.9 cm Covering length: ~ 36.5 cm ± 3 mm
Width: ~ 23.8 cm Covering width: ~ 23.8 cm
Weight: ~ 3.4 kg Requirement: ~ 2.8 pcs/m



Verge tile with outer web on left
Length: ~ 43.9 cm Covering length: ~ 36.5 cm ± 3 mm
Width: ~ 23.8 cm Covering width: ~ 21.7 cm
Weight: ~ 5.1 kg Requirement: ~ 2.8 pcs/m



Verge tile with outer web on right
Length: ~ 43.9 cm Covering length: ~ 36.5 cm ± 3 mm
Width: ~ 24.2 cm Covering width: ~ 18.0 cm
Weight: ~ 5.4 kg Requirement: ~ 2.8 pcs/m



Ridge/crest tile ~ 2.7 pieces/m
Length: ~ 43.5 cm Covering length: ~ 37.0 cm
Width: ~ 24.5 cm Covering width: ~ 21.2 cm
Weight: ~ 3.4 kg Requirement: ~ 2.7 pcs/m



Standard start ridge with end web with extended web for verge tile with outer web
Length: ~ 43.5 cm Covering length: ~ 30.5 cm
Width: ~ 24.5 cm Covering width: ~ 21.2 cm



End ridge with end web with extended web for verge tile with outer web
Length: ~ 43.5 cm Covering length: ~ 37.0 cm
Width: ~ 24.5 cm Covering width: ~ 21.2 cm



Crest initial tile
Length: ~ 43.4 cm Covering length: ~ 29.5 cm
Width: ~ 23.1 cm Covering width: ~ 21.2 cm
Weight: ~ 3.2 kg Requirement: individual



Hip cap start and end (also available with four outlets)
Requirement: individual



Shed roof tile
Length: individual Covering length: individual
Width: ~ 25.5 cm Covering width: ~ 21.5 cm



Half shed roof tile
Length: individual Covering length: individual
Width: ~ 14.6 cm Covering width: ~ 10.7 cm



Shed roof-verge tile with outer web on left
Length: individual Covering length: individual
Width: ~ 23.8 cm Covering width: ~ 21.7 cm



Shed roof-verge tile with outer web on right
Length: individual Covering length: individual
Width: ~ 24.2 cm Covering width: ~ 18.0 cm



Clay dormer ventilator (ventilation cross-section ~ 15 cm²)
Length: ~ 43.9 cm Covering length: ~ 36.5 cm ± 3 mm
Width: ~ 25.5 cm Covering width: ~ 21.5 cm
Weight: ~ 3.7 kg Requirement: individual



Ceramic vent pipe tile with weather cap ø 125 and hose with adapter
Length: ~ 43.9 cm Covering length: ~ 36.5 cm ± 3 mm
Width: ~ 25.5 cm Covering width: ~ 21.5 cm
Weight: ~ 5.0 kg Requirement: individual



Ceramic aerial tile
Length: ~ 43.9 cm Covering length: ~ 36.5 cm ± 3 mm
Width: ~ 25.5 cm Covering width: ~ 21.5 cm
Weight: ~ 4.3 kg Requirement: individual



PVC thermal exhaust gas through tile ø 100/125 (can be used up a max of 40° RP*)
Length: ~ 43.9 cm Covering length: ~ 36.5 cm ± 3 mm
Width: ~ 25.5 cm Covering width: ~ 21.5 cm



Walking grid tile PVC x 2 + walking grid
Width: ~ 34.0 cm
Length: 40.0; 80.0; 150.0 cm



SnapStep universal alu step (40 cm and 80 cm universal walking grid with two brackets also available)
coated, for mounting on different lath thicknesses, can be adjusted for roof pitches from 0° - 60°



Safety step tile, PVC
Length: ~ 43.9 cm Covering length: ~ 36.5 cm ± 3 mm
Width: ~ 25.5 cm Covering width: ~ 21.5 cm
Weight: ~ 3.6 kg Requirement: individual



Snow stop tile with round wood holder PVC
Length: ~ 43.9 cm Covering length: ~ 36.5 cm ± 3 mm
Width: ~ 25.5 cm Covering width: ~ 21.5 cm
Weight: ~ 1.2 kg Requirement: individual



Snow stop tile with snow rib support PVC
Length: ~ 43.9 cm Covering length: ~ 36.5 cm ± 3 mm
Width: ~ 25.5 cm Covering width: ~ 21.5 cm
Weight: ~ 1.2 kg Requirement: individual



PVC solar through tile
Length: ~ 43.9 cm Covering length: ~ 36.5 cm ± 3 mm
Width: ~ 25.5 cm Covering width: ~ 21.5 cm
Weight: ~ 0.7 kg ø: 30/50/70 mm



PVC solar carrier tile
Length: ~ 43.9 cm Covering length: ~ 36.5 cm ± 3 mm
Width: ~ 25.5 cm Covering width: ~ 21.5 cm
Weight: ~ 2.4 kg Requirement: individual



Light tile „Acrylic glass“
Length: ~ 43.9 cm Covering length: ~ 36.5 cm ± 3 mm
Width: ~ 25.5 cm Covering width: ~ 21.5 cm
Requirement: individual



Steel skylight, coated, 6-tiles, acrylic glazed
Length: ~ 78.0 cm Hatch: 45.0 x 55.0 cm
Width: ~ 76.0 cm Weight: ~ 8.6 kg



Multitherm skylight
Length: ~ 85.0 cm Opening: upwards + to the side
Width: ~ 78.0 cm Hatch: 44.0 x 54.0 cm
Weight: ~ 15.0 kg Double glazing: ESG Kv 1.4



Living room skylight wra
Length: ~ 98.0 cm Opening: to the side
Width: ~ 54.0 cm Hatch: 46.0 x 90.0 cm
Double glazing: ESG Kv 1.1



Eaves fresh air element
~ 1.1 pcs/m



Ridge/crest lath holder



Ridge or crest clip no. 470/41



Copper roll/Alu roll 2000
Length: ~ 5 m Width: ~ 29 cm, 33 cm, 36 cm
Ventilation cross-section: permanent acc. to DIN 4108, Part 3
Natural copper/anthracite, red



Storm clip no. 435/001 for laths 30 x 50 V2A (1)
Storm clip no. 435/002 for laths 40 x 60 V2A (1)
Storm clip no. 409/002 V2A (2)

* Over 40° RP = special design on request

Laying the twin trough gutter tile D 13.

Type of laying: Row roofing or pattern roof cladding

Technical data

| | |
|--------------------------------|------------------------------|
| Roof tile | Twin trough gutter tile D 13 |
| Manufacturer | Nelskamp (D) |
| Overall length | ~ 43.9 cm |
| Overall width | ~ 25.5 cm |
| Mean covering length | ~ 36.5 cm ± 3 mm |
| Mean covering width | ~ 21.5 cm |
| Requirement per m ² | ~ 12.8 pieces |
| Weight per tile | ~ 3.5 kg |
| Weight per m ² | ~ 45.5 kg |
| Regular roof pitch | 30° |
| Laths | 30 x 50 mm |
| Recommended storm clip | 435/001 |
| Laths | 40 x 60 mm |
| Recommended storm clip | 435/002 |

Laying!

The following applies when laying our clay roof tiles:

1. The NELSKAMP manufacturer's instructions take priority (laying instructions)
2. The specialist rules of the roofing trade (rules for coverings with clay roof tiles)
3. The German Construction Contract Procedures (VOB) (clay roof tile cover)

Material requirements for coverage

| | |
|--|---|
| Laths | ~ 3.3 m/m ² (incl. 10% waste) |
| Counter-laths | ~ 1.7 m/m ² (incl. 10% waste) |
| Roof tile | ~ 12.8 pieces/m ² |
| Packing unit* | |
| Tiles per pallet | 300 pieces |
| Tiles per stack | 30 pieces |
| Tiles per pack | 7 - 8 pieces |
| Half tile | as required, ~ 2.8 pieces/m |
| Double flap | ~ 2.8 pieces/m for left side of roof only |
| Verge tile | ~ 2.8 pieces/m |
| Walking grid tile | as required |
| Safety step tile | as required |
| Ridge or crest tile | ~ 2.7 pieces/m |
| Copper roll/Alu roll 2000 (5 m per roll) | as required |
| Ridge/crest clip 470/41 | 1.0 piece per ridge tile |
| Wood screws | 1.0 piece per ridge tile d = 4.5 mm Screw depth: 24 mm |
| Ridge or crest initial tile | 1.0 piece per ridge or crest start |
| Ridge end tile | 1.0 piece per ridge end |
| Ridge lath holder | 1.0 piece per rafter |
| Crest lath holder | 1.0 piece/ ~ 70 cm |
| Eaves fresh air element | ~ 1.1 piece/m Fresh air ~ 200 cm ² /m |

* only applies for deliveries in Germany

Regular roof pitch for clay roof tiles

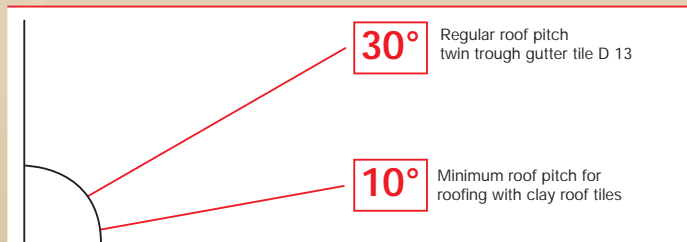

If the pitch is below the regular roof pitch the additional measures of the roofing trade rules must be carried out (cf. table).

With equivalent roof substructure alternatives: pay attention to the manufacturer's and laying instructions. Warranty must be assumed by the relevant manufacturer.

Classification of additional measures except for subordinate buildings ¹⁾ according to the technical rules of the German roofing trade, last revised January 2010

| Roof pitch | Higher requirements ²⁾ | | | |
|------------|---|---|--|--|
| | Use - Design - Climatic conditions | | | |
| | no further increased requirement ²⁾ | one further increased requirement ²⁾ | two further increased requirement ²⁾ | three further increased requirement ²⁾ |
| ≥ 30° | Class 6 3.3 Underlayment (USB- A) ⁴⁾ | Class 6 3.3 Underlayment (USB- A) ⁴⁾ | Class 5 2.4 Overlapping / interlocking undercover (UDB- A; UDB- B ⁵⁾ ; USB- A) ⁴⁾ | Class 4 2.2 Welded / bonded undercover 2.3 Undercover covered with bitumen sheeting 3.2 Underlayment secured at seams (UDB- A; UDB- B ⁵⁾ ; USB- A) ⁴⁾ |
| ≥ 26° | Class 4 2.2 Welded / bonded undercover 2.3 Undercover covered with bitumen sheeting 3.2 Underlayment secured at seams (UDB- A; UDB- B ⁵⁾ ; USB- A) ⁴⁾ | Class 4 2.2 Welded / bonded undercover 2.3 Undercover covered with bitumen sheeting 3.2 Underlayment secured at seams (UDB- A; UDB- B ⁵⁾ ; USB- A) ⁴⁾ | Class 3 2.1 Undercover secured at seams and perforations 3.1 Underlayment secured at seams and perforations (UDB- A; UDB- B ⁵⁾ ; USB- A) ⁴⁾ | Class 3 2.1 Undercover secured at seams and perforations 3.1 Underlayment secured at seams and perforations (UDB- A; UDB- B ⁵⁾ ; USB- A) ⁴⁾ |
| ≥ 22° | Class 3 2.1 Undercover secured at seams and perforations 3.1 Underlayment secured at seams and perforations (UDB- A; UDB- B ⁵⁾ ; USB- A) ⁴⁾ | Class 3 2.1 Undercover secured at seams and perforations 3.1 Underlayment secured at seams and perforations (UDB- A; UDB- B ⁵⁾ ; USB- A) ⁴⁾ | Class 3 2.1 Undercover secured at seams and perforations 3.1 Underlayment secured at seams and perforations (UDB- A; UDB- B ⁵⁾ ; USB- A) ⁴⁾ | Class 3 ³⁾ 2.1 Undercover secured at seams and perforations 3.1 Underlayment secured at seams and perforations (UDB- A; UDB- B ⁵⁾ ; USB- A) ⁴⁾ |
| ≥ 18° | Class 2 1.2 Rainproof roof substructure | Class 2 1.2 Rainproof roof substructure | Class 1 1.1 Waterproof roof substructure | Class 1 1.1 Waterproof roof substructure |
| ≥ 10° | Class 1 1.1 Waterproof roof substructure | Class 1 1.1 Waterproof roof substructure | Class 1 1.1 Waterproof roof substructure | Class 1 1.1 Waterproof roof substructure |
| MRP | 10° | | | |

¹⁾ The additional measures named in the table are minimum measures taking into account table 1 of the "Leaflet for roof substructures, undercovers, underlays".

²⁾ Higher requirements form categories in accordance with Section 1.1.3. Further higher requirements may result from the weighting within a category according to Section 1.1.3. For example, climatic conditions can lead to several higher requirements.

³⁾ Only allowed if proof has been rendered of the functional reliability of the products used including accessories (sealing tapes, adhesive tapes, sealing compounds, ready-made seam protection, etc.) by the manufacturer during a driving rain test. The next highest class should otherwise be chosen.

⁴⁾ Undercover plates are to be assigned according to the classification in the "Leaflet for roof substructures, undercovers and underlays".

⁵⁾ If indices 2), 3), 4), 5) in the product data sheet are met:

2) Resistance to driving rain, proven by the "Driving rain test underlay and undercover sheets - TU Berlin"

3) Higher requirements on ageing are proven by increasing the temperature in the test method Appendix C 5.2 of DIN EN 13859- 1 to 80 °C.

4) The manufacturer specifies the duration of the outdoor weathering period whilst warranting the aforementioned properties.

5) The manufacturer confirms the suitability as a provisional cover and specifies the duration of the outdoor weathering period whilst warranting the aforementioned properties.

Covering widths

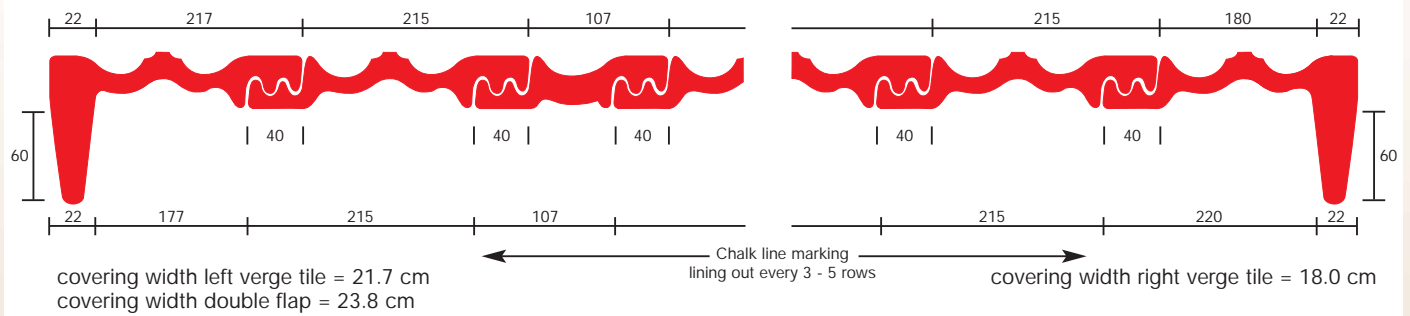

Roof lathing in conjunction with ridge flaps (dry ridge)

Supporting laths:

The following min. cross-sections must be used:
(rules for roofing, notes on wood and timber materials)

| Nom. cross-sections of support laths | Rafter intervals (unit spacing) | Sizing class |
|--------------------------------------|---------------------------------|--------------|
| 30 x 50 mm | ≤ 80 cm | S 10 |
| 40 x 60 mm | ≤ 100 cm | S 10 |

Counter-laths:

Rec. thickness of counter-laths acc. to rules for roofing
(notes on wood and timber materials):

| Rafter length | Rec. thickness |
|---------------|----------------|
| up to 8 m | 24 mm |
| up to 12 m | 30 mm |
| over 12 m | 40 mm |

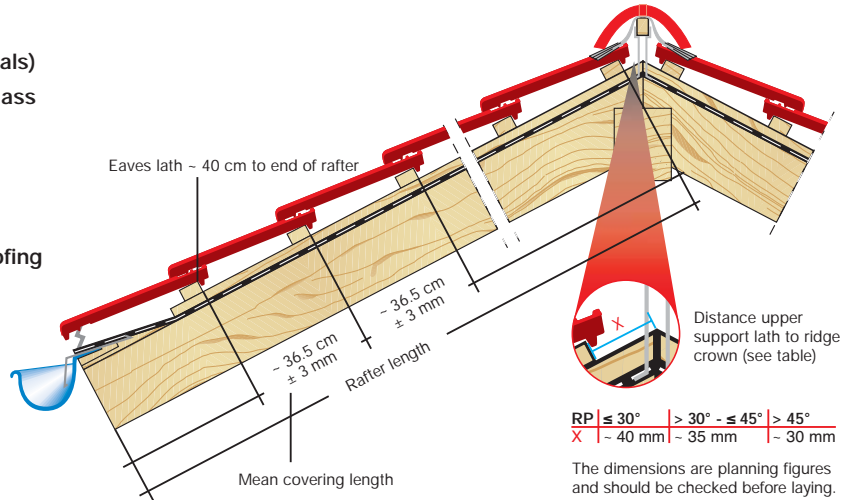

Details eaves design

The dimensions are planning figures and should be checked before laying depending on the design and local circumstances.

1 With gutter & vent element

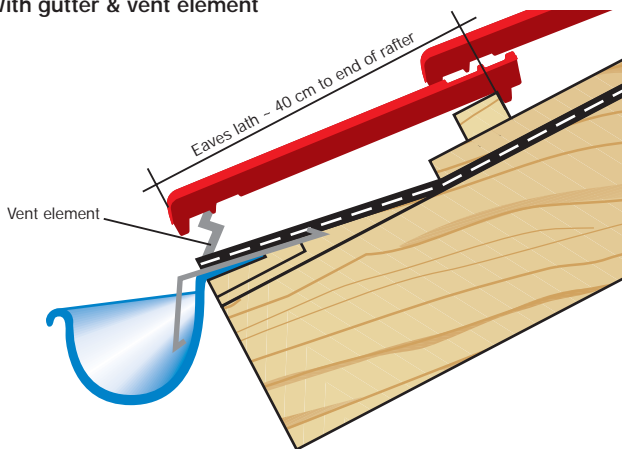

2 High-level gutter (recommended for flat roof pitches < 22°)

Tile overhang in gutter max. 1/3 of gutter width

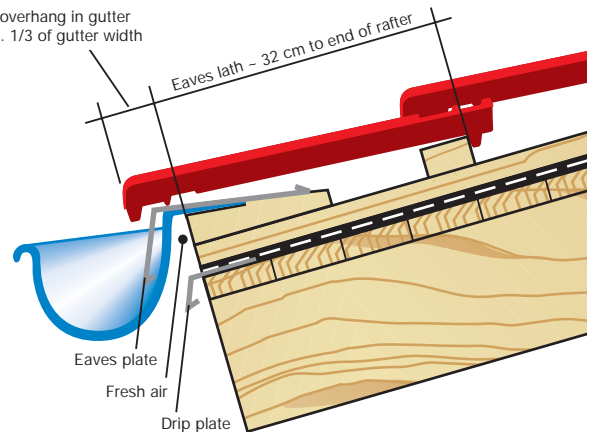

Ridge/crest details

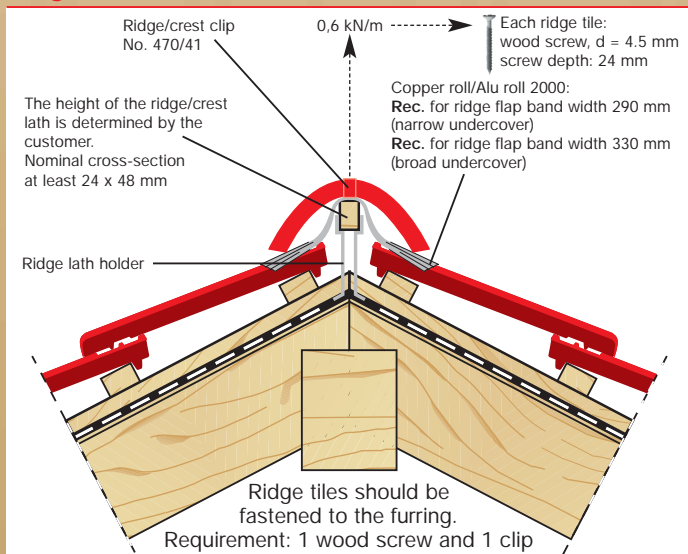

Verge details

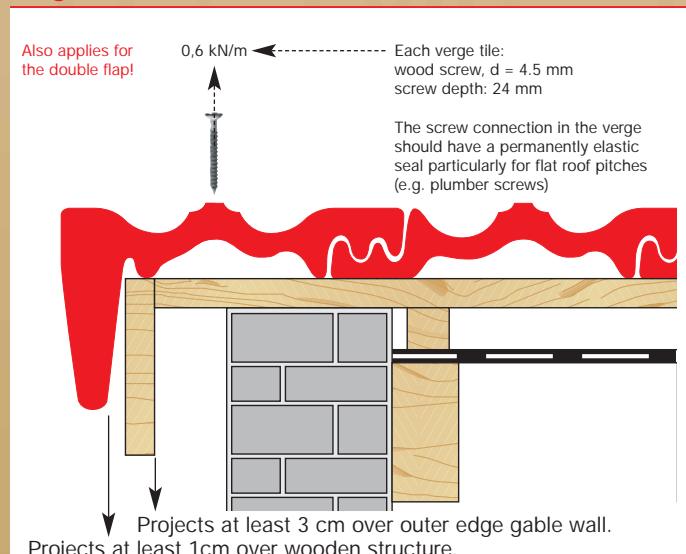

Shed roof tile

Shed roof tiles should be fastened to the furring (see detail verge).

(1) The length should normally be determined in the water rabbet.

Size sheets can be downloaded from the internet or on the data service CD

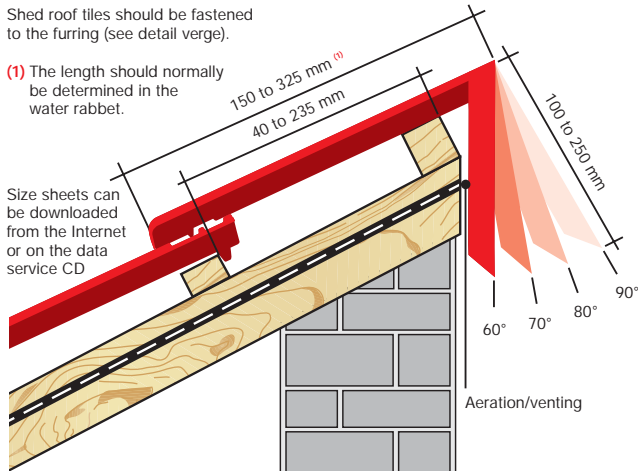

90°

- longest size 325 mm results in a mean lath size 255 mm

- shortest size 150 mm results in a mean lath size 80 mm

80° = RP 10°

- longest size 310 mm results in a mean lath size 230 mm

- shortest size 160 mm results in a mean lath size 80 mm

70° = RP 20°

- longest size 320 mm results in a mean lath size 235 mm

- shortest size 150 mm results in a mean lath size 65 mm

60° = RP 30°

- longest size 325 mm results in a mean lath size 215 mm

- shortest size 150 mm results in a mean lath size 40 mm

Installation instructions for safety step tile/walking grid tile/snow stop tile

Every safety step tile/walking grid tile must be provided with an additional supporting-safety lath (same lath cross-section as supporting laths). **Fastening to supporting lath:** two corrosion-proof wood screws (4.5 x 45 mm per tile)

Processing acc. to DIN 18160-5

| Article | ≤ 45° | > 45° |
|-------------------|------------------------------------|--------------------|
| Walking grid tile | every 2 nd row of tiles | every row of tiles |
| Safety step tile | every row of tiles | every row of tiles |

tested to DIN EN 516

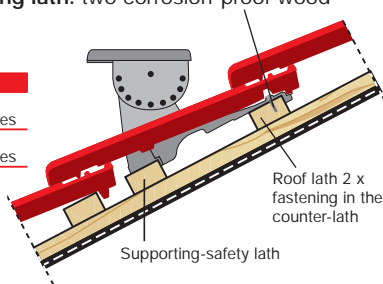

The same applies for interlocking tiles with snow rib or round wood holder, whereby the max. support spacing should not exceed 90 cm. For higher demands you should reduce the support spacing (60 cm).

Aeration and ventilation in steep roof

- 1 Eaves fresh air element
- 2 Copper roll/Alu roll 2000
- 3 Clay dormer ventilator with fitted screen vent cross-section ~ 15 cm²

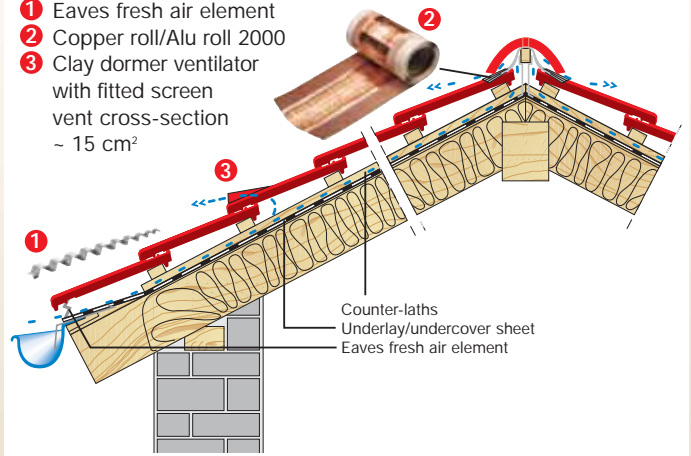

1) The vent cross-section at the eaves should be at least 200 cm²/m of eaves.

2) The vent cross-section at the ridge or crest should be at least 0.5% of the total corresponding roof area, though at least 50 cm². (according to DIN 4108-3)

Installation instructions for universal alu step

A chase is made in the head and foot interlocking joint of the gutter tile using a right angle grinder with diamond wheel to lead through the stainless steel suspension hinge. Hang the alu mounting bracket in the throat of the gutter tile so that the two rubber profiles with the lower end of the mounting bracket lie on the roof lath.

The rubber profiles must rest where the gutter tiles overlap.

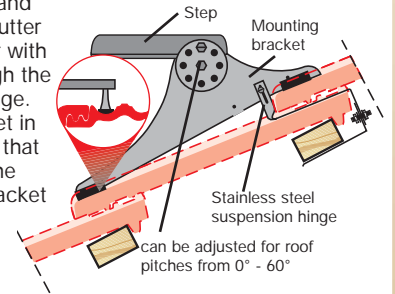

Installation instructions on delivery

tested to DIN EN 516

Storm clips

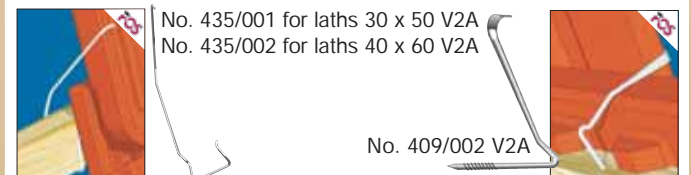

According to professional standards, we can supply storm clips for a simple and effective protection against wind suction. They can alternatively be clipped to the laths or knocked into the laths. Resistant to corrosion through stainless steel wire 1.4301 (A2) or ZIAL® coating (corrosion protection).

On the NELSKAMP data service CD or as a download on the Internet from www.nelskamp.de

- Product specifications
- Laying instructions
- CAD data

DOWNLOAD



For colourful, clean roofs. The Nelskamp concrete roofing tile program.

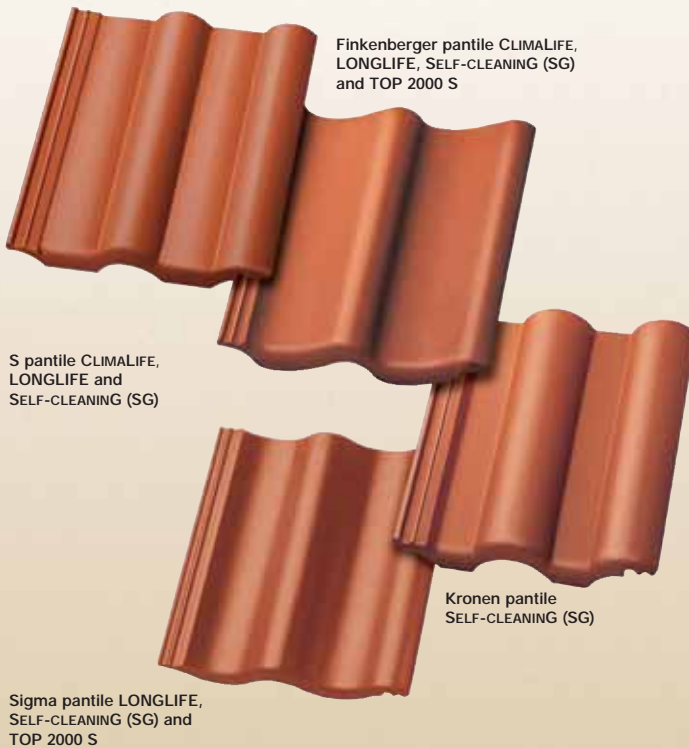

CLIMALIFE concrete roofing tiles

With their ClimaLife surface our roof pantiles clean our environment from contaminants resulting from heating, traffic and the industry. Up to 90 percent are neutralized in daylight, without sunlight up to 70 percent. This is due to the titanium oxide content in the micro concrete. It mainly converts nitrogen oxides (NO_x) into harmless substances like NO₃⁻. Again and again, because titanium oxide is a catalyst, which is never used up. The rain does the rest: It just flushes away the substances, which then are harmless.

LONGLIFE concrete roofing tiles

The leading technology of LONGLIFE concrete roofing tiles is based on the smooth surface of micro-concrete and a newly developed, silk-gloss colour coating. Both factors ensure clean roofs with long-lasting, intensive colours. The reason: dirt is washed off by rain and moss or algae find almost no base for growth.

SELF-CLEANING (SG) concrete roofing tiles

SG = Self-cleaninG concrete roofing tiles are also supplied with the newly developed colour coating. Moss and algae find almost no base for growth on the surface.

TOP 2000 S concrete roofing tiles

High-quality raw materials, the latest production methods and established coating technologies with numerous standard and special colours are characteristic of TOP 2000 S concrete roofing tiles.



Concrete roofing tiles and clay roof tiles from Nelskamp. The obvious solution.

Our strategically placed production facilities guarantee that our roof building materials are always well received. Six plants throughout Germany are the sound, logistical basis for co-operation and help spare the environment.

Administration and sales

Waldweg 6 · D-46514 Schermbeck
Postfach 11 20 · D-46510 Schermbeck
Phone: +49 28 53/91 30-0
Fax: +49 28 53/37 59
Email: vertrieb@nelskamp.de
Internet: www.nelskamp.de

Production of concrete roofing tiles

Gartrop Works
Gahlener Straße 158
D-46569 Hünxe-Gartrop
Phone: +49 28 53/91 30-31/32
Fax: +49 28 53/45 59

Dieburg Works
Lagerstraße 30
D-64807 Dieburg
Phone: +49 60 71/98 64-0
Fax: +49 60 71/16 73

Schönerlinde Works
Schönerlinder Bahnhofstraße 6
D-16348 Wandlitz
Phone: +49 30/94 03 91-0
Fax: +49 30/94 12 20 4

Production of clay roof tiles

Schermbeck Works
Waldweg 6
D-46514 Schermbeck
Phone: +49 28 53/91 30-23/17
Fax: +49 28 53/26 70

Unsleben Works
Wechterswinkler Straße 23
D-97618 Unsleben
Phone: +49 97 73/9 10 10
Fax: +49 97 73/7 49

Groß-Ammensleben Works
Magdeburger Straße 42
D-39326 Groß-Ammensleben
Phone: +49 3 92 02/88-6
Fax: +49 3 92 02/88 80 2

From clay. From concrete. From experience.

NELSKAMP