

The twin trough gutter tile D 13

Type of laying: Row roofing or pattern roof cladding

Technical data

Roof tile	Twin trough gutter tile D 13
Manufacturer	Nelskamp (D)
Overall length	~ 43.9 cm
Overall width	~ 25.5 cm
Mean covering length	~ 36.5 cm ± 3 mm
Mean covering width	~ 21.5 cm
Requirement per m ²	~ 12.8 pieces
Weight per tile	~ 3.5 kg
Weight per m ²	~ 45.5 kg
Regular roof pitch	30°
Laths	30 x 50 mm
Recommended storm clip	435/001
Laths	40 x 60 mm
Recommended storm clip	435/002



The Colours

natural red, red engobed, brown engobed, black noble engobed (matt black glazed), wine red engobed, muscat noble engobed (glazed), old black engobed

Laying!

The following applies when laying our clay roof tiles:

1. The NELSKAMP manufacturer's instructions take priority (laying instructions)
2. The specialist rules of the roofing trade (rules for coverings with clay roof tiles)
3. The German Construction Contract Procedures (VOB) (clay roof tile cover)

Material requirements for coverage

Laths	~ 3.3 m/m ² (incl. 10% waste)
Counter-laths	~ 1.7 m/m ² (incl. 10% waste)
Roof tile	~ 12.8 pieces/m ²
Packing unit*	
Tiles per pallet	300 pieces
Tiles per stack	30 pieces
Tiles per pack	7 - 8 pieces
Half tile	as required, ~ 2.8 pieces/m
Double flap	~ 2.8 pieces/m for left side of roof only
Verge tile	~ 2.8 pieces/m
Walking grid tile	as required
Safety step tile	as required
Ridge or crest tile	~ 2.7 pieces/m
Copper roll/Alu roll 2000 (5 m per roll)	as required
Ridge/crest clip 470/41	1.0 piece per ridge tile
Wood screws	1.0 piece per ridge tile d = 4.5 mm Screw depth: 24 mm
Ridge or crest initial tile	1.0 piece per ridge or crest start
Ridge end tile	1.0 piece per ridge end
Ridge lath holder	1.0 piece per rafter
Crest lath holder	1.0 piece/ ~ 70 cm
Eaves fresh air element	~ 1.1 piece/m Fresh air ~ 200 cm ² /m

* only applies for deliveries in Germany

Storm clips

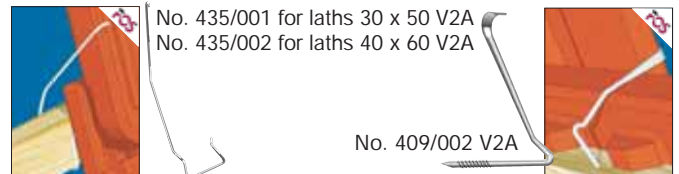

According to professional standards, we can supply storm clips for a simple and effective protection against wind suction. They can alternatively be clipped to the laths or knocked into the laths. Resistant to corrosion through stainless steel wire 1.4301 (A2) or ZIAL® coating (corrosion protection).

Covering widths

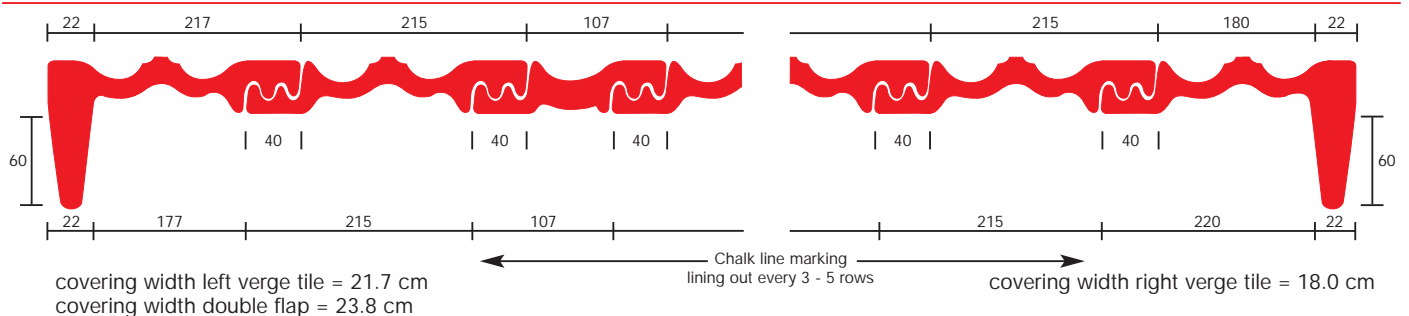

Classification of additional measures except for subordinate buildings ¹⁾ according to the technical rules of the German roofing trade, last revised January 2010

Roof pitch	Higher requirements ²⁾			
	Use - Design - Climatic conditions			
	no further increased requirement ²⁾	one further increased requirement ²⁾	two further increased requirement ²⁾	three further increased requirement ²⁾
≥ 30°	Class 6 3.3 Underlayment (USB- A) ⁴⁾	Class 6 3.3 Underlayment (USB- A) ⁴⁾	Class 5 2.4 Overlapping / interlocking undercover (UDB- A; UDB- B ⁵⁾ ; USB- A) ⁴⁾	Class 4 2.2 Welded / bonded undercover 2.3 Undercover covered with bitumen sheeting 3.2 Underlayment secured at seams (UDB- A; UDB- B ⁵⁾ ; USB- A) ⁴⁾
≥ 26°	Class 4 2.2 Welded / bonded undercover 2.3 Undercover covered with bitumen sheeting 3.2 Underlayment secured at seams (UDB- A; UDB- B ⁵⁾ ; USB- A) ⁴⁾	Class 4 2.2 Welded / bonded undercover 2.3 Undercover covered with bitumen sheeting 3.2 Underlayment secured at seams (UDB- A; UDB- B ⁵⁾ ; USB- A) ⁴⁾	Class 3 2.1 Undercover secured at seams and perforations 3.1 Underlayment secured at seams and perforations (UDB- A; UDB- B ⁵⁾ ; USB- A) ⁴⁾	Class 3 2.1 Undercover secured at seams and perforations 3.1 Underlayment secured at seams and perforations (UDB- A; UDB- B ⁵⁾ ; USB- A) ⁴⁾
≥ 22°	Class 3 2.1 Undercover secured at seams and perforations 3.1 Underlayment secured at seams and perforations (UDB- A; UDB- B ⁵⁾ ; USB- A) ⁴⁾	Class 3 2.1 Undercover secured at seams and perforations 3.1 Underlayment secured at seams and perforations (UDB- A; UDB- B ⁵⁾ ; USB- A) ⁴⁾	Class 3 2.1 Undercover secured at seams and perforations 3.1 Underlayment secured at seams and perforations (UDB- A; UDB- B ⁵⁾ ; USB- A) ⁴⁾	Class 3 ³⁾ 2.1 Undercover secured at seams and perforations 3.1 Underlayment secured at seams and perforations (UDB- A; UDB- B ⁵⁾ ; USB- A) ⁴⁾
≥ 18°	Class 2 1.2 Rainproof roof substructure	Class 2 1.2 Rainproof roof substructure	Class 1 1.1 Waterproof roof substructure	Class 1 1.1 Waterproof roof substructure
≥ 10°	Class 1 1.1 Waterproof roof substructure	Class 1 1.1 Waterproof roof substructure	Class 1 1.1 Waterproof roof substructure	Class 1 1.1 Waterproof roof substructure
MRP	10°			

- 1) The additional measures named in the table are minimum measures taking into account table 1 of the "Leaflet for roof substructures, undercovers, underlays".
- 2) Higher requirements form categories in accordance with Section 1.1.3. Further higher requirements may result from the weighting within a category according to Section 1.1.3. For example, climatic conditions can lead to several higher requirements.
- 3) Only allowed if proof has been rendered of the functional reliability of the products used including accessories (sealing tapes, adhesive tapes, sealing compounds, ready-made seam protection, etc.) by the manufacturer during a driving rain test. The next highest class should otherwise be chosen.
- 4) Undercover plates are to be assigned according to the classification in the "Leaflet for roof substructures, undercovers and underlays".
- 5) If indices 2), 3), 4), 5) in the product data sheet are met:
 - 2) Resistance to driving rain, proven by the "Driving rain test underlay and undercover sheets - TU Berlin"
 - 3) Higher requirements on ageing are proven by increasing the temperature in the test method Appendix C 5.2 of DIN EN 13859- 1 to 80 °C.
 - 4) The manufacturer specifies the duration of the outdoor weathering period whilst warranting the aforementioned properties.
 - 5) The manufacturer confirms the suitability as a provisional cover and specifies the duration of the outdoor weathering period whilst warranting the aforementioned properties.

Roof lathing in conjunction with ridge flaps (dry ridge)

Supporting laths:

The following min. cross-sections must be used:
(rules for roofing, notes on wood and timber materials)

Nom. cross-sections of support laths	Rafter intervals (unit spacing)	Sizing class
30 x 50 mm	≤ 80 cm	S 10
40 x 60 mm	≤ 100 cm	S 10

Counter-laths:

Rec. thickness of counter-laths acc. to rules for roofing
(notes on wood and timber materials):

Rafter length	Rec. thickness
up to 8 m	24 mm
up to 12 m	30 mm
over 12 m	40 mm

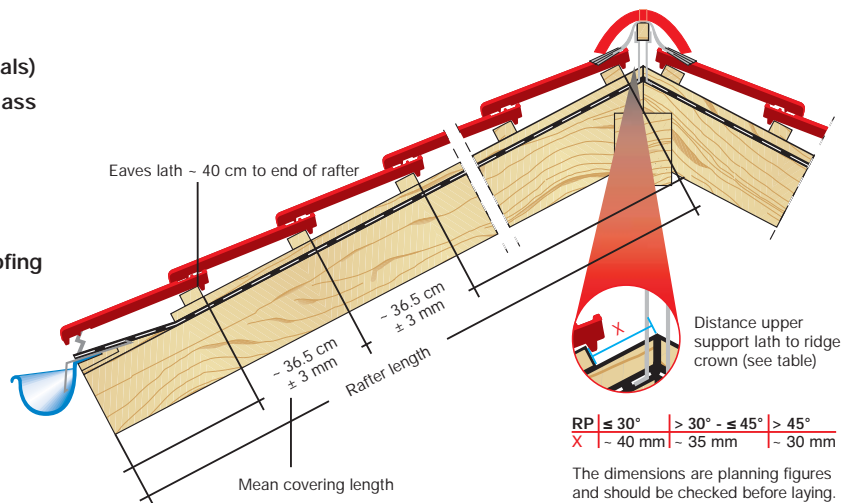

Details eaves design

The dimensions are planning figures and should be checked before laying depending on the design and local circumstances.

1 With gutter & vent element

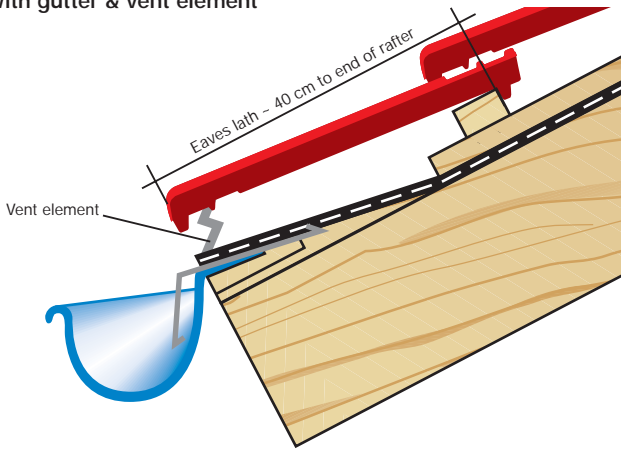

2 High-level gutter (recommended for flat roof pitches < 22°)

Tile overhang in gutter max. 1/3 of gutter width

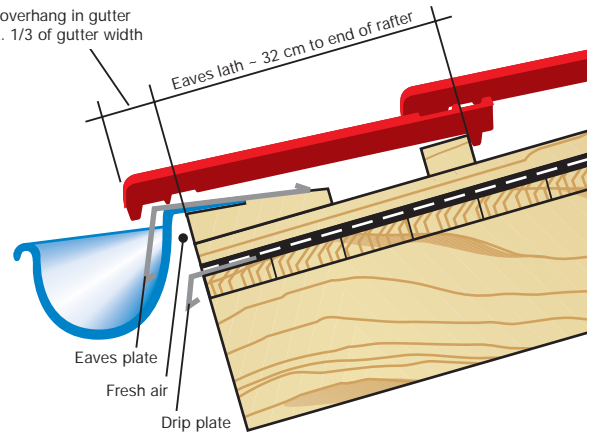

Ridge/crest details

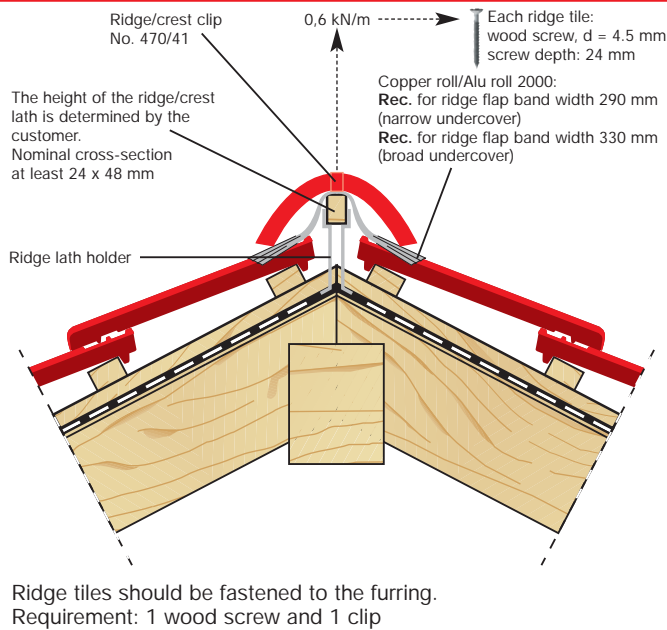

Verge details

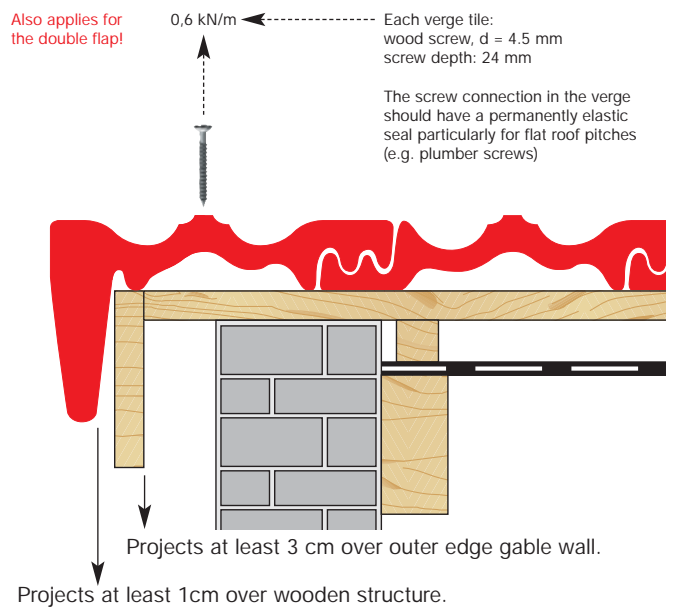

Installation instructions for safety step tile/walking grid tile/snow stop tile

Every safety step tile/walking grid tile must be provided with an additional supporting-safety lath (same lath cross-section as supporting laths). **Fastening to supporting lath:** two corrosion-proof wood screws (4.5 x 45 mm per tile)

Processing acc. to DIN 18160-5

Article	≤ 45°	> 45°
Walking grid tile	every 2 nd row of tiles	every row of tiles
Safety step tile	every row of tiles	every row of tiles

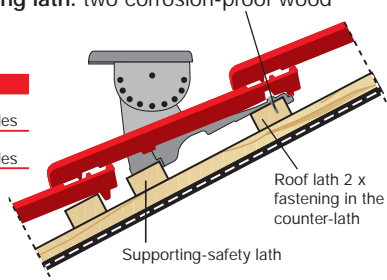

tested to DIN EN 516

Installation instructions for universal alu step

A chase is made in the head and foot interlocking joint of the gutter tile using a right angle grinder with diamond wheel to lead through the stainless steel suspension hinge. Hang the alu mounting bracket in the throat of the gutter tile so that the two rubber profiles with the lower end of the mounting bracket lie on the roof lath. The rubber profiles must rest where the gutter tiles overlap.

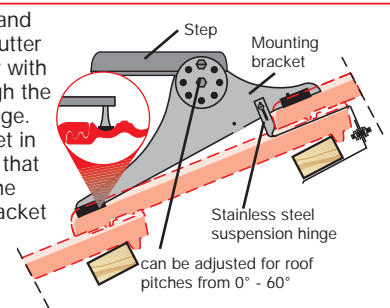

Installation instructions on delivery

tested to DIN EN 516

The same applies for interlocking tiles with snow rib or round wood holder, whereby the max. support spacing should not exceed 90 cm. For higher demands you should reduce the support spacing (60 cm).

Shed roof tile

Shed roof tiles should be fastened to the furring (see detail verge).

(1) The length should normally be determined in the water rabbet.

Size sheets can be downloaded from the Internet or on the data service CD

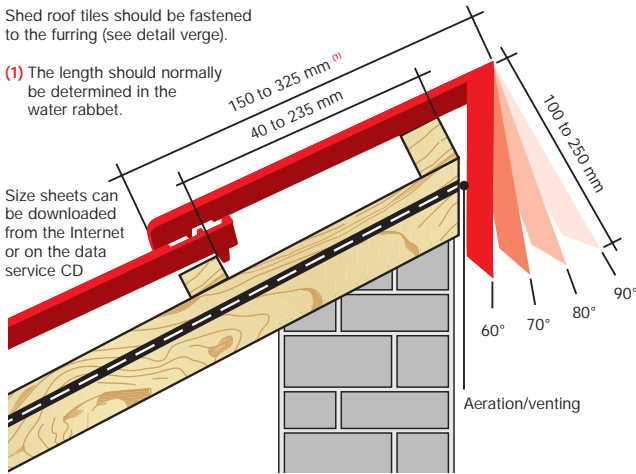

90°

- longest size 325 mm results in a mean lath size 255 mm

- shortest size 150 mm results in a mean lath size 80 mm

80° = RP 10°

- longest size 310 mm results in a mean lath size 230 mm

- shortest size 160 mm results in a mean lath size 80 mm

70° = RP 20°

- longest size 320 mm results in a mean lath size 235 mm

- shortest size 150 mm results in a mean lath size 65 mm

60° = RP 30°

- longest size 325 mm results in a mean lath size 215 mm

- shortest size 150 mm results in a mean lath size 40 mm

Aeration and ventilation in steep roof

- 1 Eaves fresh air element
- 2 Copper roll/Alu roll 2000
- 3 Clay dormer ventilator with fitted screen
vent cross-section
~ 15 cm²

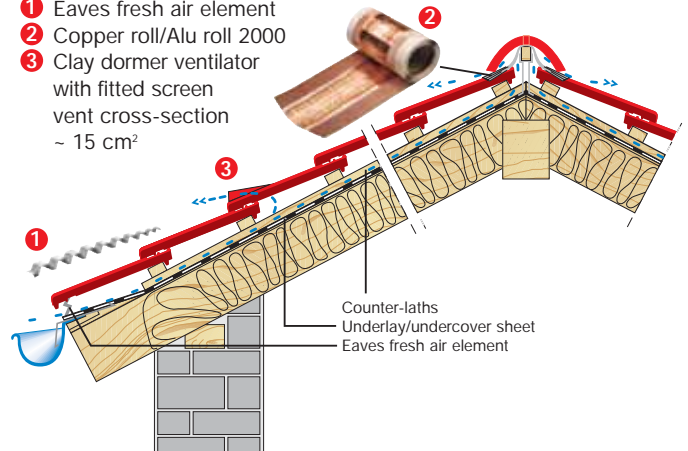

1) The vent cross-section at the eaves should be at least 200 cm²/m of eaves.

2) The vent cross-section at the ridge or crest should be at least 0.5‰ of the total corresponding roof area, though at least 50 cm².

(according to DIN 4108-3)