

Technical data

Roof tile	Flat roof tile F 12 Ü
Manufacturer	Nelskamp (D)
Overall length	~ 45.7 cm
Overall width	~ 28.6 cm
Mean covering length	~ 34.5 cm ± 20 mm
Mean covering width	~ 23.6 cm
Requirement per m ²	~ 11.7 - 13.0 pieces
Weight per tile	~ 3.8 kg
Weight per m ²	~ 44.5 kg
Regular roof pitch	22°
Recommended storm clip	Multi storm claw



The Colours

natural red, red engobed, brown engobed, bordeaux red engobed, black noble engobed (matt black glazed), muscat noble engobed (glazed), burgundy red noble engobed (glazed), old black engobed, copper red engobed, brown noble engobed (glazed)

Material requirements for coverage

Laths	~ 3.2 m/m ² (incl. 10% waste)
Counter-laths	~ 1.7 m/m ² (incl. 10% waste)
Roof tile	~ 11.7 pieces/m ² (covering length 36.5 cm) ~ 12.3 pieces/m ² (covering length 34.5 cm) ~ 13.0 pieces/m ² (covering length 32.5 cm)

Packing unit*

Tiles per pallet	288 pieces
Tiles per stack	36 pieces (72 pieces)
Tiles per pack	6 pieces
Verge tile	~ 2.9 pieces/m
Ridge or crest tile	~ 2.7 pieces/m
Copper roll/Alu roll 2000 (5 m per roll)	as required
Ridge/crest clip 470/41	1.0 piece per ridge tile
Wood screws	1.0 piece per ridge tile d = 4.5 mm Screw depth: 24 mm
Ridge or crest initial tile	1.0 piece per ridge or crest start
Ridge end tile	1.0 piece per ridge end
Ridge lath holder	1.0 piece per rafter
Crest lath holder	1.0 piece/ ~ 70 cm
Eaves fresh air element	~ 1.1 piece/m Fresh air ~ 200 cm ² /m

* only applies for deliveries in Germany

Laying!

The following applies when laying our clay roof tiles:

1. The NELSKAMP manufacturer's instructions take priority (laying instructions)
2. The specialist rules of the roofing trade (rules for coverings with clay roof tiles)
3. The German Construction Contract Procedures (VOB) (clay roof tile cover)

Covering widths

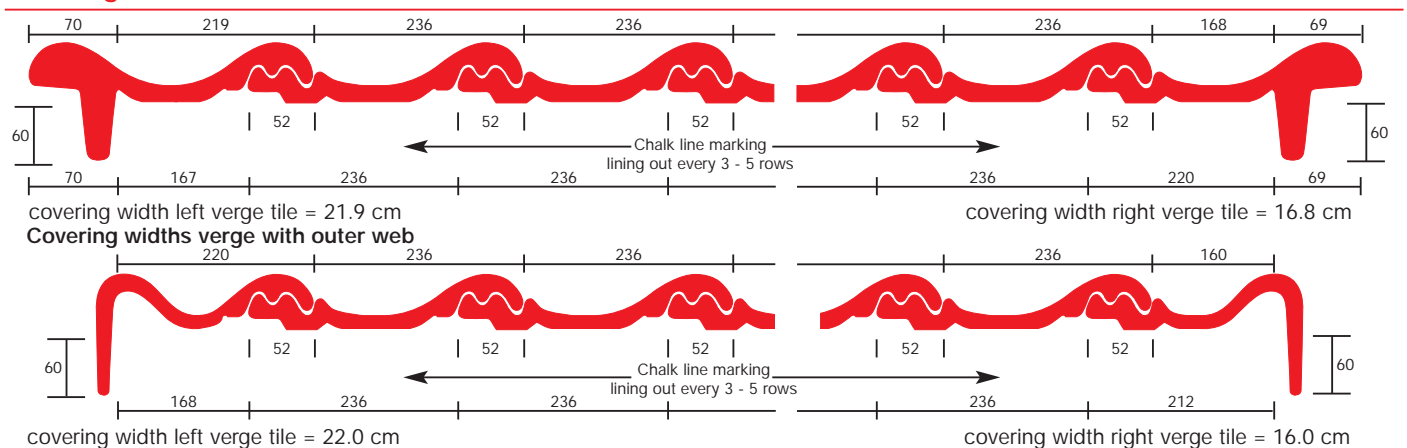

Classification of additional measures except for subordinate buildings ¹⁾ according to the technical rules of the German roofing trade, last revised January 2010

Roof pitch	Higher requirements ²⁾			
	Use - Design - Climatic conditions			
	no further increased requirement ²⁾	one further increased requirement ²⁾	two further increased requirement ²⁾	three further increased requirement ²⁾
≥ 22°	Class 6 3.3 Underlayment (USB- A) ⁴⁾	Class 6 3.3 Underlayment (USB- A) ⁴⁾	Class 5 2.4 Overlapping / interlocking undercover (UDB- A; UDB- B ⁵⁾ ; USB- A) ⁴⁾	Class 4 2.2 Welded / bonded undercover 2.3 Undercover covered with bitumen sheeting 3.2 Underlayment secured at seams (UDB- A; UDB- B ⁵⁾ ; USB- A) ⁴⁾
≥ 18°	Class 4 2.2 Welded / bonded undercover 2.3 Undercover covered with bitumen sheeting 3.2 Underlayment secured at seams (UDB- A; UDB- B ⁵⁾ ; USB- A) ⁴⁾	Class 4 2.2 Welded / bonded undercover 2.3 Undercover covered with bitumen sheeting 3.2 Underlayment secured at seams (UDB- A; UDB- B ⁵⁾ ; USB- A) ⁴⁾	Class 3 2.1 Undercover secured at seams and perforations 3.1 Underlayment secured at seams and perforations (UDB- A; UDB- B ⁵⁾ ; USB- A) ⁴⁾	Class 3 2.1 Undercover secured at seams and perforations 3.1 Underlayment secured at seams and perforations (UDB- A; UDB- B ⁵⁾ ; USB- A) ⁴⁾
≥ 14°	Class 3 2.1 Undercover secured at seams and perforations 3.1 Underlayment secured at seams and perforations (UDB- A; UDB- B ⁵⁾ ; USB- A) ⁴⁾	Class 3 2.1 Undercover secured at seams and perforations 3.1 Underlayment secured at seams and perforations (UDB- A; UDB- B ⁵⁾ ; USB- A) ⁴⁾	Class 3 2.1 Undercover secured at seams and perforations 3.1 Underlayment secured at seams and perforations (UDB- A; UDB- B ⁵⁾ ; USB- A) ⁴⁾	Class 3 ³⁾ 2.1 Undercover secured at seams and perforations 3.1 Underlayment secured at seams and perforations (UDB- A; UDB- B ⁵⁾ ; USB- A) ⁴⁾
≥ 10°	Class 2 1.2 Rainproof roof substructure	Class 2 1.2 Rainproof roof substructure	Class 1 1.1 Waterproof roof substructure	Class 1 1.1 Waterproof roof substructure
MRP			10°	

- 1) The additional measures named in the table are minimum measures taking into account table 1 of the "Leaflet for roof substructures, undercovers, underlays".
- 2) Higher requirements form categories in accordance with Section 1.1.3. Further higher requirements may result from the weighting within a category according to Section 1.1.3. For example, climatic conditions can lead to several higher requirements.
- 3) Only allowed if proof has been rendered of the functional reliability of the products used including accessories (sealing tapes, adhesive tapes, sealing compounds, ready-made seam protection, etc.) by the manufacturer during a driving rain test. The next highest class should otherwise be chosen.
- 4) Undercover plates are to be assigned according to the classification in the "Leaflet for roof substructures, undercovers and underlays".
- 5) If indices 2), 3), 4), 5) in the product data sheet are met:
 - 2) Resistance to driving rain, proven by the "Driving rain test underlay and undercover sheets - TU Berlin"
 - 3) Higher requirements on ageing are proven by increasing the temperature in the test method Appendix C 5.2 of DIN EN 13859- 1 to 80 °C.
 - 4) The manufacturer specifies the duration of the outdoor weathering period whilst warranting the aforementioned properties.
 - 5) The manufacturer confirms the suitability as a provisional cover and specifies the duration of the outdoor weathering period whilst warranting the aforementioned properties.

Roof lathing in conjunction with ridge flaps (dry ridge)

Supporting laths:

The following min. cross-sections must be used:
(rules for roofing, notes on wood and timber materials)

Nom. cross-sections of support laths	Rafter intervals (unit spacing)	Sizing class
30 x 50 mm	≤ 80 cm	S 10
40 x 60 mm	≤ 100 cm	S 10

Counter-laths:

Rec. thickness of counter-laths acc. to rules for roofing
(notes on wood and timber materials):

Rafter length	Rec. thickness
up to 8 m	24 mm
up to 12 m	30 mm
over 12 m	40 mm

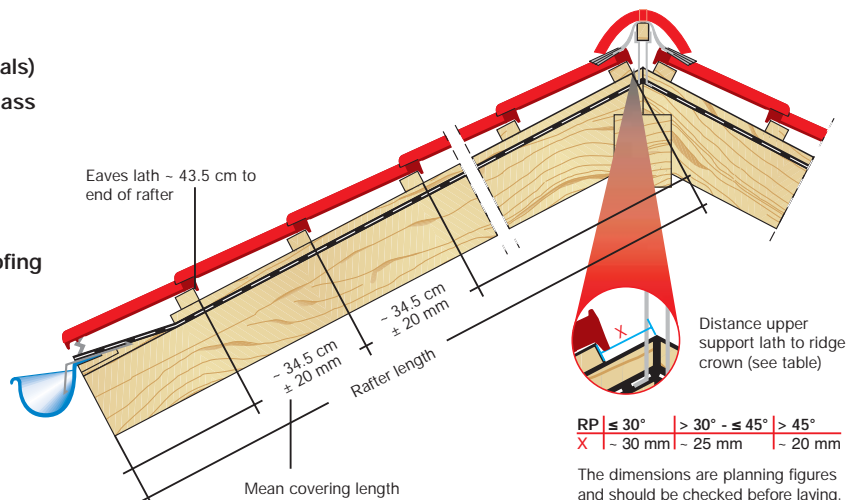

Details eaves design

The dimensions are planning figures and should be checked before laying depending on the design and local circumstances.

1 With gutter & vent element

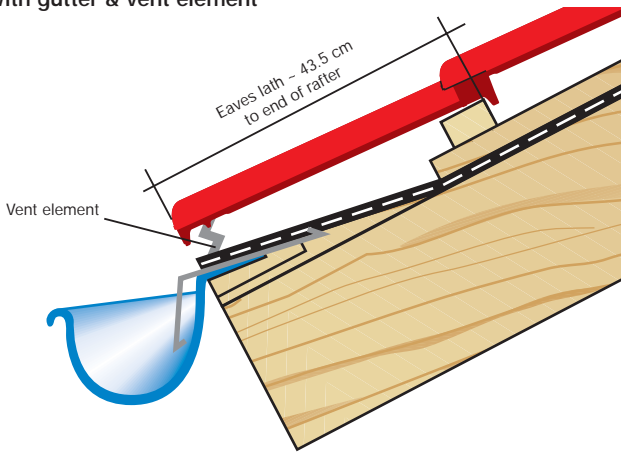

2 High-level gutter (recommended for flat roof pitches < 22°)

Tile overhang in gutter max. 1/3 of gutter width

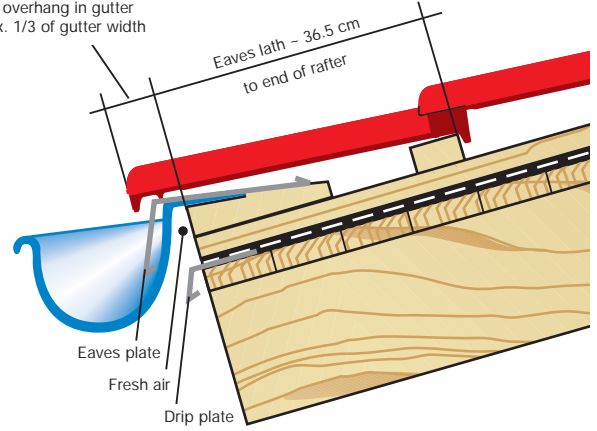

Ridge/crest details

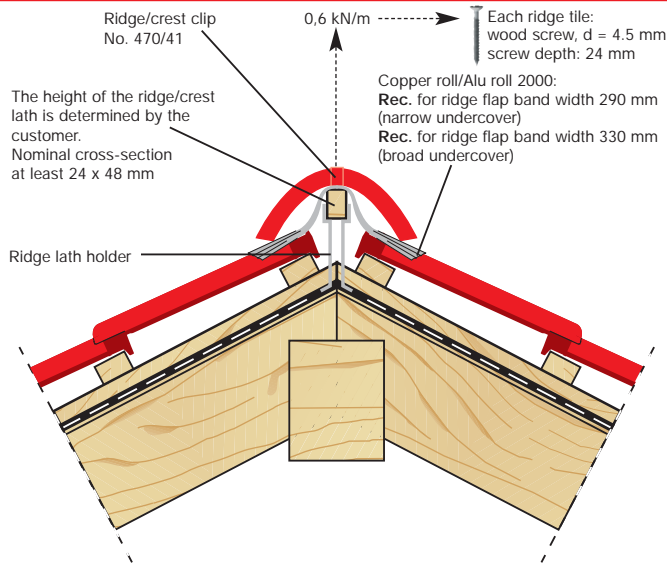

Ridge tiles should be fastened to the furring. Requirement: 1 wood screw and 1 clip

Verge details

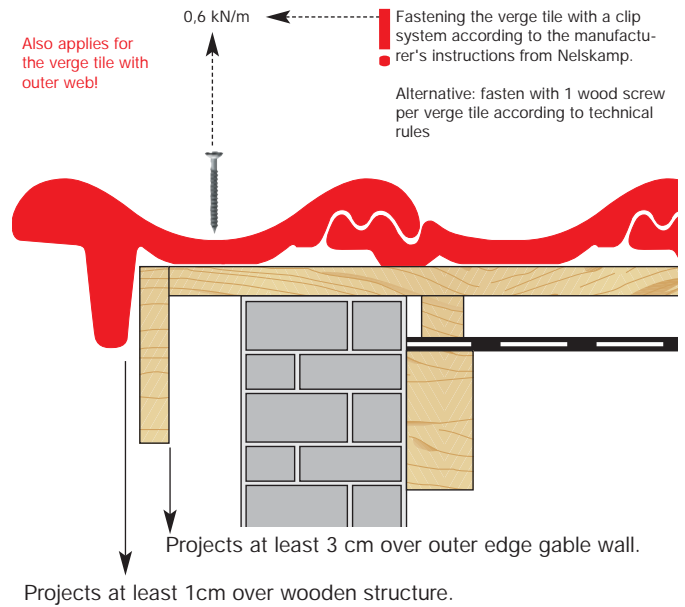

Shed roof tile

Shed roof tiles should be fastened to the furring (see detail verge).

Size sheets can be downloaded from the Internet or on the data service CD

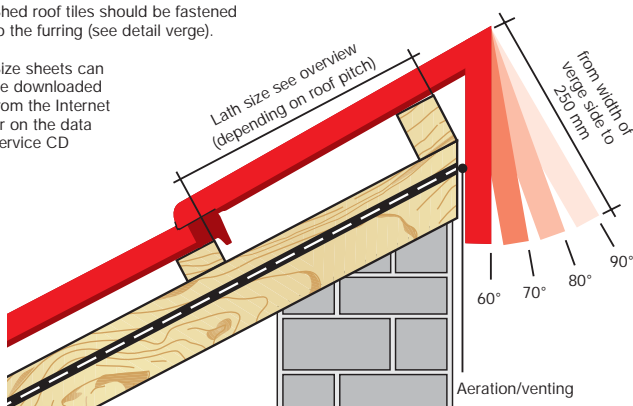

Overview lath size:

- 90°**
 - maximum lath size of 225 mm
 - minimum lath size of 90 mm
- 80° = RP 10°**
 - maximum lath size of 210 mm
 - minimum lath size of 90 mm
- 70° = RP 20°**
 - maximum lath size of 190 mm
 - minimum lath size of 90 mm
- 60° = RP 30°**
 - maximum lath size of 165 mm
 - minimum lath size of 90 mm

Aeration and ventilation in steep roof

- 1 Eaves fresh air element
- 2 Copper roll/Alu roll 2000
- 3 Clay dormer ventilator with fitted screen vent cross-section ~ 15 cm²

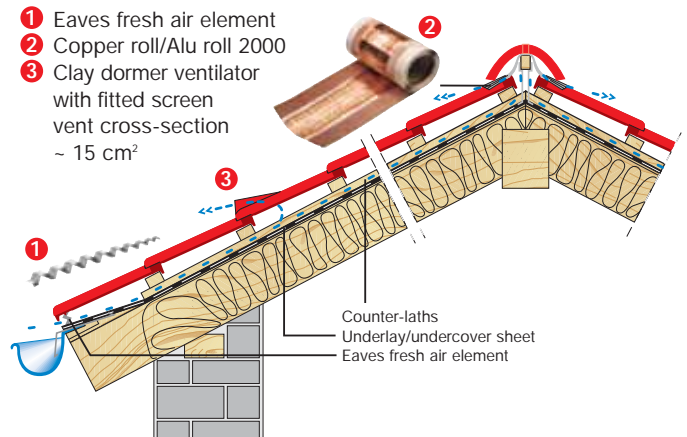

- 1) The vent cross-section at the eaves should be at least 200 cm²/m of eaves.
- 2) The vent cross-section at the ridge or crest should be at least 0.5‰ of the total corresponding roof area, though at least 50 cm². (according to DIN 4108-3)

Laying instructions for ridge connecting tile (with standard ridge tile)

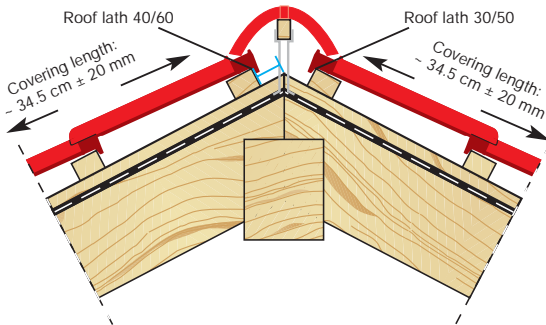

Ridge design with ridge connecting tiles

Upper edge 1st lath from ridge crown		
up to 30° RP	Laths 30 x 50 mm	4.0 cm
up to 30° RP	Laths 40 x 60 mm	4.0 cm
up to 45° RP	Laths 30 x 50 mm	2.0 cm
up to 45° RP	Laths 40 x 60 mm	2.0 cm
over 50° RP	Laths 30 x 50 mm	2.0 cm
over 50° RP	Laths 40 x 60 mm	2.0 cm

The dimensions are planning figures and should be checked before laying.

Mansard and pent roof tile

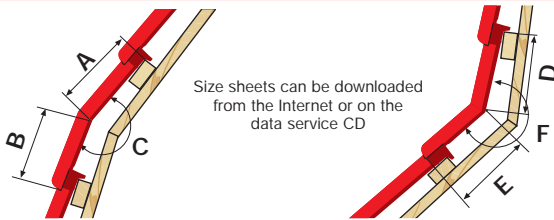

Size sheets can be downloaded from the Internet or on the data service CD

Installation instructions for alu base tile with single step/walking grid tile/snow stop tile

Of stainless steel/aluminium. No supporting laths needed!

Fastening to supporting lath: Aluminium tile fastened to lath with 2 screws (V2A screw included)

Processing acc. to DIN 18160-5

Article	≤ 45°	> 45°
Walking grid tile	every 2 nd row of tiles	every row of tiles
Alu base tile w step tile	every row of tiles	every row of tiles

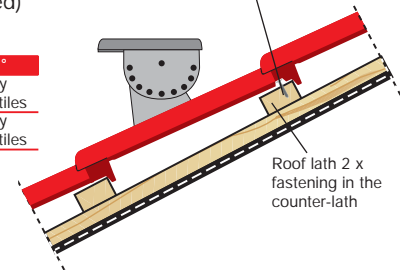

tested to DIN EN 516

The same applies for alu pantiles with snow rib or round wood holder, whereby the max. support spacing should not exceed 90 cm. For higher demands you should reduce the support spacing (60 cm).

Installation instructions for universal alu step

A chase is made in the head and foot interlocking joint of the gutter tile using a right angle grinder with diamond wheel to lead through the stainless steel suspension hinge. Hang the alu mounting bracket in the throat of the gutter tile so that the two rubber profiles with the lower end of the mounting bracket lie on the roof lath.

The rubber profiles must rest where the gutter tiles overlap.

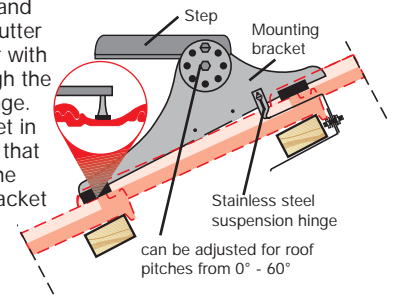

Installation instructions on delivery

tested to DIN EN 516

Multi storm claw

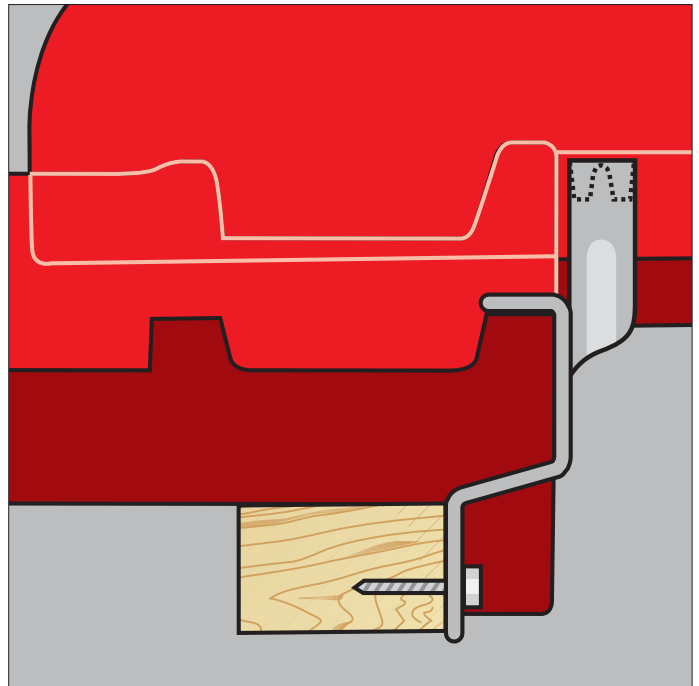
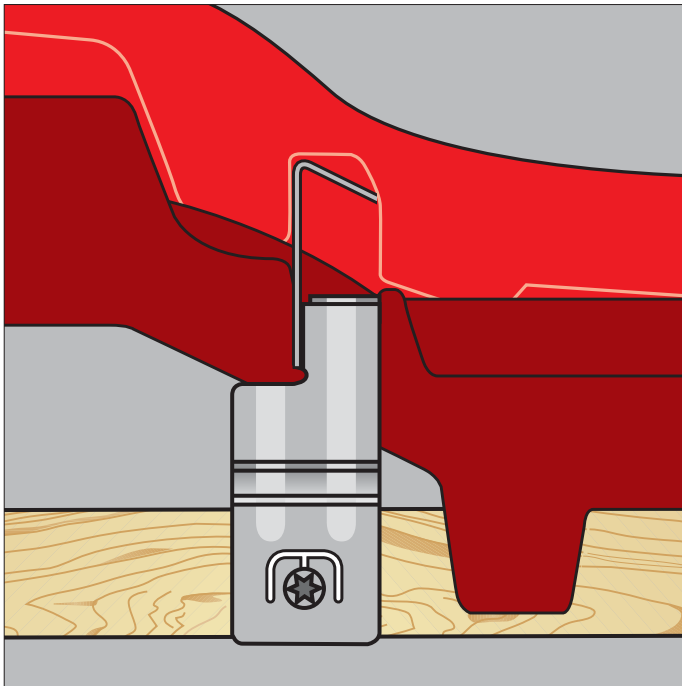

That's new:

Maximum protection against wind suction and easy installation:

The multi storm claw is placed on top of the gutter tile at the appropriate point and screwed to the laths. The roof tiles remain **completely free of screw holes that could impair their function**. There is a clay groove pressed into the underside of the tile where the multi storm claw can be clipped into place. After screwing into place the next overlapping tile is simply laid in position. The multi storm claw audibly clips/grips the clay groove after a slight pressure is exerted on the tile. The multi storm claw ensures a combined (2-fold) fastening of the roof tile at its top and bottom.

The pull-out values of former common side rabbit clips are greatly exceeded. The tiles are fastened in place absolutely stormproof in accordance with the technical rules for roofing.

