

From clay. From concrete. From experience.

NELSKAMP

Flat roof tile F 13 Classic



The flat roof tile F 13 Classic.



The F 13 Classic is the larger version of the tried and trusted F 15. The F 13 Classic satisfies the wish for calm, harmonious roof areas with less laying work.

- The F 13 Classic in detail:**
- Pressed roof tile according to DIN/EN 1304
 - Twin head and side trough
 - Waterproof, frost-resistant, breathable
 - Regular roof pitch 22°
 - Requirement per m² approx. 12.2 pcs



The Colours.



(156) red engobed



(118) brown engobed



(120) black noble engobed
(matt black glazed)



(124) wine red engobed



(126) zinc grey noble engobed (glazed)



(129) mocca brown noble engobed
(glazed)



(139) muscat noble engobed (glazed)

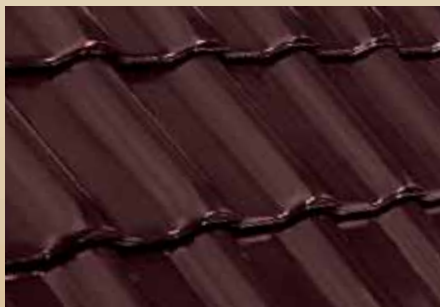

(140) burgundy red noble engobed (glazed)



(141) old black engobed

Colour deviations: Our clay roof tiles are environment-friendly building materials. When using natural raw materials you may experience colour deviations. This is often the case with naturally red tiles since the fired colour is the sole result of natural raw materials with no added metal oxides to change the colour. Deviations are possible in the colours for reasons of printing methods.

Clay roof tile surfaces: Minor impairments to the surface are possible due to transport. This does not affect the quality of the tiles.

The program.

Moulded bricks for various functions meet the demand for homogeneous, architecturally demanding roofs. They are also an important safety factor. Moulded bricks and accessories reduce the amount of laying work and

facilitate calculations. You will find the complete program for every tile on our Internet website www.nelskamp.de.

	Whole tile Length: ~ 43.8 cm Width: ~ 28.5 cm Weight: ~ 3.4 kg	Covering length: ~ 36.2 cm ± 5 mm Covering width: ~ 22.4 cm Requirement: ~ 12.2 pcs/m ²
	Double flap Length: ~ 43.8 cm Width: ~ 28.5 cm Weight: ~ 3.6 kg	Covering length: ~ 36.2 cm ± 5 mm Covering width: ~ 28.5 cm Requirement: ~ 3.0 pcs/m
	Left verge tile Length: ~ 43.8 cm Width: ~ 28.7 cm Weight: ~ 5.1 kg	Covering length: ~ 36.2 cm ± 5 mm Covering width: ~ 21.2 cm Requirement: ~ 3.0 pcs/m
	Right verge tile Length: ~ 43.8 cm Width: ~ 28.3 cm Weight: ~ 5.0 kg	Covering length: ~ 36.2 cm ± 5 mm Covering width: ~ 14.8 cm Requirement: ~ 3.0 pcs/m
	Ridge/crest tile ~ 2.7 pieces/m Length: ~ 43.5 cm Width: ~ 24.5 cm Weight: ~ 3.4 kg	Covering length: ~ 37.0 cm Covering width: ~ 21.2 cm Requirement: ~ 2.7 pcs/m
	Start ridge with offset end web for verge tile with offset ridge Length: ~ 43.5 cm Width: ~ 24.5 cm	Covering length: ~ 30.5 cm Covering width: ~ 21.2 cm
	Ridge end with offset end web for verge tile with offset ridge Length: ~ 43.5 cm Width: ~ 24.5 cm	Covering length: ~ 37.0 cm Covering width: ~ 21.2 cm
	Crest initial tile Length: ~ 43.4 cm Width: ~ 23.1 cm Weight: ~ 3.2 kg	Covering length: ~ 29.5 cm Covering width: ~ 21.2 cm Requirement: individual
	Hip cap start and end (also available with four outlets) Requirement: individual	
	Clay dormer ventilator (ventilation cross-section ~ 15 cm²) Length: ~ 43.8 cm Width: ~ 28.5 cm Weight: ~ 3.8 kg	Covering length: ~ 36.2 cm ± 5 mm Covering width: ~ 22.4 cm Requirement: individual
	Ridge connection sliding tile (left/right verge tiles also available) Max. displacement range 8.0 cm Length: ~ 43.8 cm Width: ~ 28.5 cm	Covering length: ~ 36.2 cm ± 5 mm Covering width: ~ 22.4 cm
	Shed roof tile (left/right verge tiles also available) Length: individual Width: ~ 28.5 cm Weight: ~ 3.2 kg	Covering length: individual Covering width: ~ 22.4 cm
	Mansard tile (left/right verge tiles also available) Length: individual Width: ~ 28.5 cm	Covering length: individual Covering width: ~ 22.4 cm
	Pent roof tile (left/right verge tiles also available) Length: individual Width: ~ 28.5 cm	Covering length: individual Covering width: ~ 22.4 cm
	Ceramic vent pipe tile with weather cap ø 125 and hose with adapter Length: ~ 43.8 cm Width: ~ 28.5 cm Weight: ~ 5.5 kg	Covering length: ~ 36.2 cm ± 5 mm Covering width: ~ 22.4 cm Requirement: individual
	Ceramic aerial tile Length: ~ 43.8 cm Width: ~ 28.5 cm Weight: ~ 3.9 kg	Covering length: ~ 36.2 cm ± 5 mm Covering width: ~ 22.4 cm Requirement: individual
	PVC thermal exhaust gas through tile ø 100/125 (can be used up a max of 45° RP*) Length: ~ 43.8 cm Width: ~ 28.5 cm	Covering length: ~ 36.2 cm ± 5 mm Covering width: ~ 22.4 cm

	PVC solar through tile Length: ~ 43.8 cm Width: ~ 28.5 cm Weight: ~ 0.7 kg	Covering length: ~ 36.2 cm ± 5 mm Covering width: ~ 22.4 cm ø: 30/50/70 mm
	PVC solar carrier tile Length: ~ 43.8 cm Width: ~ 28.5 cm Weight: ~ 2.4 kg	Covering length: ~ 36.2 cm ± 5 mm Covering width: ~ 22.4 cm Requirement: individual
	Light tile „Acrylic glass“ Length: ~ 43.8 cm Width: ~ 28.5 cm	Covering length: ~ 36.2 cm ± 5 mm Covering width: ~ 22.4 cm Requirement: individual
	2 Alu-walking grid tile, coated Width: ~ 34.0 cm Length: 40.0; 80.0; 150.0 cm	
	SnapStep universal alu step (40 cm and 80 cm universal walking grid with two brackets also available) coated, for mounting on different lath thicknesses, can be adjusted for roof pitches from 0° - 60°	
	Alu base tile with single step Length: ~ 43.8 cm Width: ~ 28.5 cm	Covering length: ~ 36.2 cm ± 5 mm Covering width: ~ 22.4 cm Requirement: individual
	Alu base pantile with twin tube holder Length: ~ 43.8 cm Width: ~ 28.5 cm	Covering length: ~ 36.2 cm ± 5 mm Covering width: ~ 22.4 cm Requirement: individual
	Alu tile with round wood holder Length: ~ 43.8 cm Width: ~ 28.5 cm	Covering length: ~ 36.2 cm ± 5 mm Covering width: ~ 22.4 cm Requirement: individual
	Alu tile with snow rib support Length: ~ 43.8 cm Width: ~ 28.5 cm	Covering length: ~ 36.2 cm ± 5 mm Covering width: ~ 22.4 cm Requirement: individual
	Steel skylight, coated, 6-tiles, acrylic glazed Length: ~ 78.0 cm Width: ~ 76.0 cm	Hatch: 45.0 x 55.0 cm Weight: ~ 8.6 kg
	Steel skylight, coated, 9-tiles, acrylic glazed Length: ~ 110.0 cm Width: ~ 76.0 cm	Hatch: 45.0 x 85.0 cm Weight: ~ 10.0 kg
	Multitherm skylight Length: ~ 85.0 cm Width: ~ 78.0 cm Weight: ~ 15.0 kg	Opening: upwards + to the side Hatch: 44.0 x 54.0 cm Double glazing: ESG Kv 1.4
	Living room skylight wra Length: ~ 98.0 cm Width: ~ 54.0 cm	Opening: to the side Hatch: 46.0 x 90.0 cm Double glazing: ESG Kv 1.1
	Eaves fresh air element ~ 1.1 pcs/m	
	Ridge/crest lath holder	
	Ridge or crest clip no. 470/41	
	Copper roll/Alu roll 2000 Length: ~ 5 m Width: ~ 29 cm, 33 cm, 36 cm	Ventilation cross-section: permanent acc. to DIN 4108, Part 3 Natural copper/anthracite, red
	Storm clip no. 435/001 for laths 30 x 50 V2A (1) Storm clip no. 435/002 for laths 40 x 60 V2A (1) Storm clip no. 409/002 V2A (2)	

All sizes are approx. sizes. Tolerances according to DIN EN 1304. Covering sizes are to be determined on site. Subject to technical changes.

* Over 45° RP = special design on request

Laying the flat roof tile F 13 Classic.

Technical data

Roof tile	Flat roof tile F 13 Classic
Manufacturer	Nelskamp (D)
Overall length	~ 43.8 cm
Overall width	~ 28.5 cm
Mean covering length	~ 36.2 cm ± 5 mm
Mean covering width	~ 22.4 cm
Requirement per m ²	~ 12.2 pieces
Weight per tile	~ 3.4 kg
Weight per m ²	~ 41.5 kg
Regular roof pitch	22°
Laths	30 x 50 mm
Recommended storm clip	435/001
Laths	40 x 60 mm
Recommended storm clip	435/002

Laying!

The following applies when laying our clay roof tiles:

1. The NELSKAMP manufacturer's instructions take priority (laying instructions)
2. The specialist rules of the roofing trade (rules for coverings with clay roof tiles)
3. The German Construction Contract Procedures (VOB) (clay roof tile cover)

Material requirements for coverage

Laths	~ 3.3 m/m ² (incl. 10% waste)
Counter-laths	~ 1.7 m/m ² (incl. 10% waste)
Roof tile	~ 12.2 pieces/m ²
Packing unit*	
Tiles per pallet	296 pieces
Tiles per stack	37 pieces
Tiles per pack	7 - 8 pieces
Double flap	~ 3.0 pieces/m for left side of roof only
Verge tile	~ 3.0 pieces/m
Ridge or crest tile	~ 2.7 pieces/m
Copper roll/Alu roll 2000 (5 m per roll)	as required
Ridge/crest clip 470/41	1.0 piece per ridge tile
Wood screws	1.0 piece per ridge tile d = 4.5 mm Screw depth: 24 mm
Ridge or crest initial tile	1.0 piece per ridge or crest start
Ridge end tile	1.0 piece per ridge end
Ridge lath holder	1.0 piece per rafter
Crest lath holder	1.0 piece/ ~ 70 cm
Eaves fresh air element	~ 1.1 piece/m Fresh air ~ 200 cm ² /m

* only applies for deliveries in Germany

Regular roof pitch for clay roof tiles

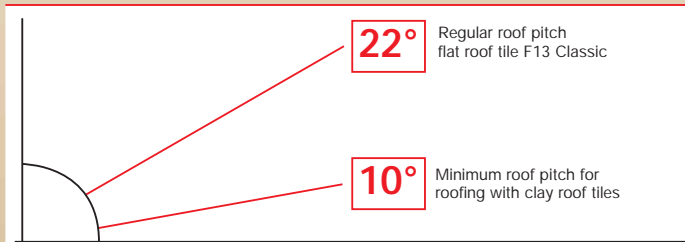

If the pitch is below the regular roof pitch the additional measures of the roofing trade rules must be carried out (cf. table).

With equivalent roof substructure alternatives: pay attention to the manufacturer's and laying instructions. Warranty must be assumed by the relevant manufacturer.

Classification of additional measures except for subordinate buildings ¹⁾ according to the technical rules of the German roofing trade, last revised January 2010

Roof pitch	Higher requirements ²⁾			
	Use - Design - Climatic conditions			
	no further increased requirement ²⁾	one further increased requirement ²⁾	two further increased requirement ²⁾	three further increased requirement ²⁾
≥ 22°	Class 6 3.3 Underlayment (USB- A) ⁴⁾	Class 6 3.3 Underlayment (USB- A) ⁴⁾	Class 5 2.4 Overlapping / interlocking undercover (UDB- A; UDB- B ⁵⁾ ; USB- A) ⁴⁾	Class 4 2.2 Welded / bonded undercover 2.3 Undercover covered with bitumen sheeting 3.2 Underlayment secured at seams (UDB- A; UDB- B ⁵⁾ ; USB- A) ⁴⁾
≥ 18°	Class 4 2.2 Welded / bonded undercover 2.3 Undercover covered with bitumen sheeting 3.2 Underlayment secured at seams (UDB- A; UDB- B ⁵⁾ ; USB- A) ⁴⁾	Class 4 2.2 Welded / bonded undercover 2.3 Undercover covered with bitumen sheeting 3.2 Underlayment secured at seams (UDB- A; UDB- B ⁵⁾ ; USB- A) ⁴⁾	Class 3 2.1 Undercover secured at seams and perforations 3.1 Underlayment secured at seams and perforations (UDB- A; UDB- B ⁵⁾ ; USB- A) ⁴⁾	Class 3 2.1 Undercover secured at seams and perforations 3.1 Underlayment secured at seams and perforations (UDB- A; UDB- B ⁵⁾ ; USB- A) ⁴⁾
≥ 14°	Class 3 2.1 Undercover secured at seams and perforations 3.1 Underlayment secured at seams and perforations (UDB- A; UDB- B ⁵⁾ ; USB- A) ⁴⁾	Class 3 2.1 Undercover secured at seams and perforations 3.1 Underlayment secured at seams and perforations (UDB- A; UDB- B ⁵⁾ ; USB- A) ⁴⁾	Class 3 2.1 Undercover secured at seams and perforations 3.1 Underlayment secured at seams and perforations (UDB- A; UDB- B ⁵⁾ ; USB- A) ⁴⁾	Class 3 ³⁾ 2.1 Undercover secured at seams and perforations 3.1 Underlayment secured at seams and perforations (UDB- A; UDB- B ⁵⁾ ; USB- A) ⁴⁾
≥ 10°	Class 2 1.2 Rainproof roof substructure	Class 2 1.2 Rainproof roof substructure	Class 1 1.1 Waterproof roof substructure	Class 1 1.1 Waterproof roof substructure
MRP			10°	

¹⁾ The additional measures named in the table are minimum measures taking into account table 1 of the "Leaflet for roof substructures, undercovers, underlays".

²⁾ Higher requirements form categories in accordance with Section 1.1.3. Further higher requirements may result from the weighting within a category according to Section 1.1.3. For example, climatic conditions can lead to several higher requirements.

³⁾ Only allowed if proof has been rendered of the functional reliability of the products used including accessories (sealing tapes, adhesive tapes, sealing compounds, ready-made seam protection, etc.) by the manufacturer during a driving rain test. The next highest class should otherwise be chosen.

⁴⁾ Undercover plates are to be assigned according to the classification in the "Leaflet for roof substructures, undercovers and underlays".

⁵⁾ If indices 2), 3), 4), 5) in the product data sheet are met:

2) Resistance to driving rain, proven by the "Driving rain test underlay and undercover sheets - TU Berlin"

3) Higher requirements on ageing are proven by increasing the temperature in the test method Appendix C 5.2 of DIN EN 13859- 1 to 80 °C.

4) The manufacturer specifies the duration of the outdoor weathering period whilst warranting the aforementioned properties.

5) The manufacturer confirms the suitability as a provisional cover and specifies the duration of the outdoor weathering period whilst warranting the aforementioned properties.

Covering widths

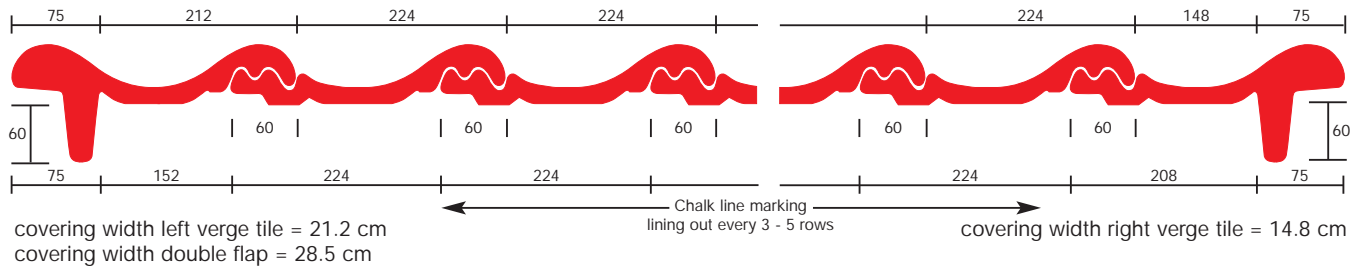

Roof lathing in conjunction with ridge flaps (dry ridge)

Supporting laths:

The following min. cross-sections must be used:
(rules for roofing, notes on wood and timber materials)

Nom. cross-sections of support laths	Rafter intervals (unit spacing)	Sizing class
30 x 50 mm	≤ 80 cm	S 10
40 x 60 mm	≤ 100 cm	S 10

Counter-laths:

Rec. thickness of counter-laths acc. to rules for roofing
(notes on wood and timber materials):

Rafter length	Rec. thickness
up to 8 m	24 mm
up to 12 m	30 mm
over 12 m	40 mm

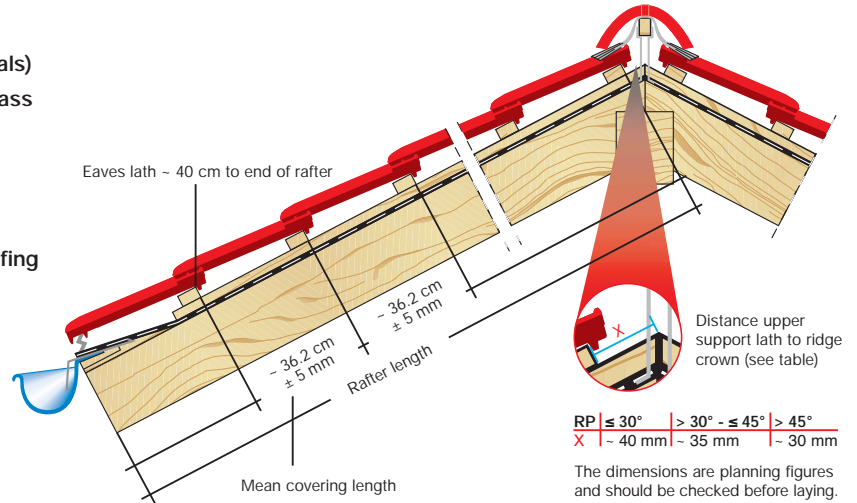

Details eaves design

The dimensions are planning figures and should be checked before laying depending on the design and local circumstances.

1 With gutter & vent element

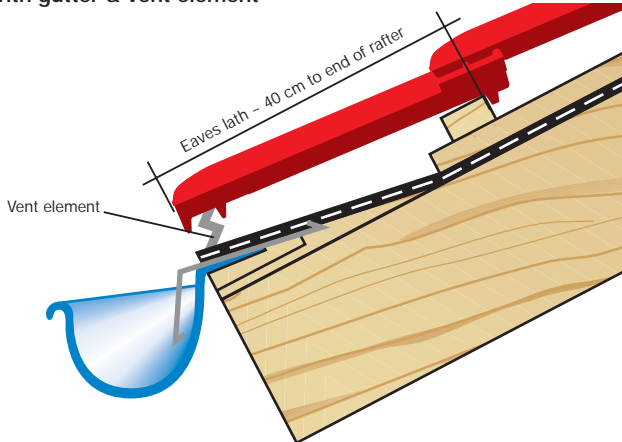

2 High-level gutter (recommended for flat roof pitches < 22°)

Tile overhang in gutter max. 1/3 of gutter width

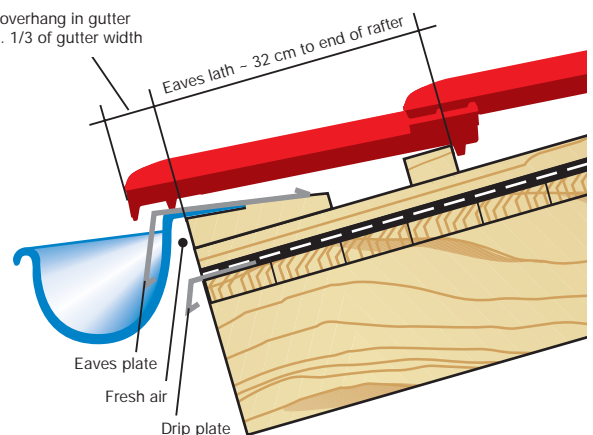

Ridge/crest details

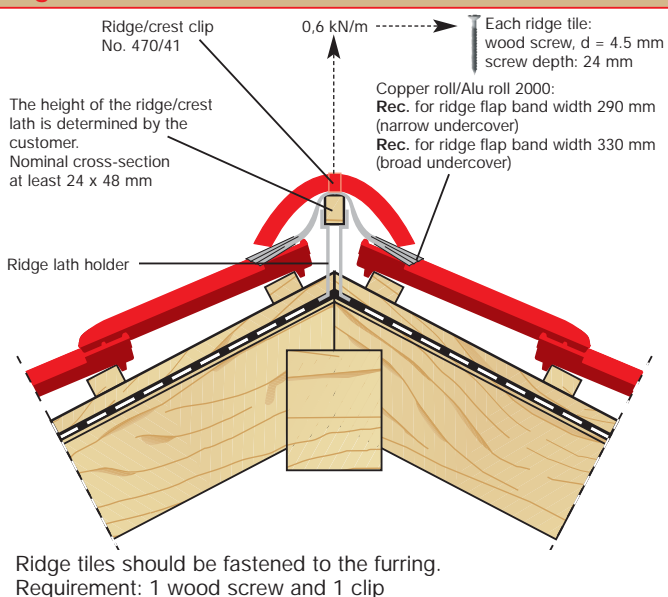

Verge details

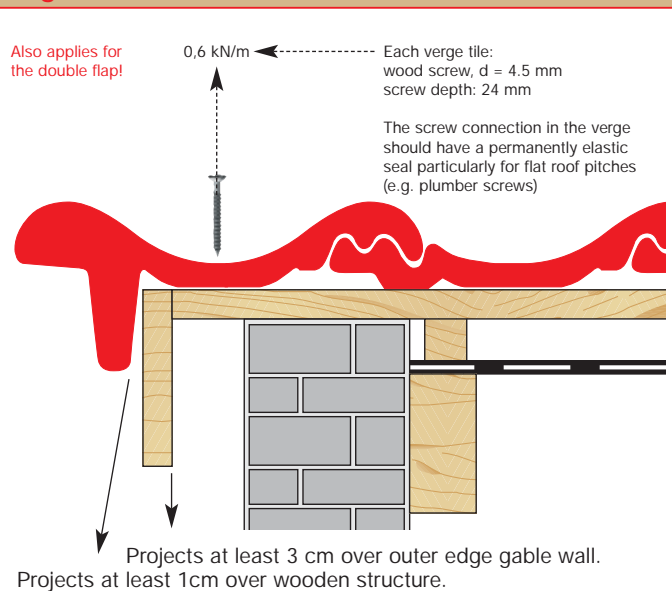

Shed roof tile

Shed roof tiles should be fastened to the furring (see detail verge).

(1) The length should normally be determined in the water rabbit.

Size sheets can be downloaded from the Internet or on the data service CD

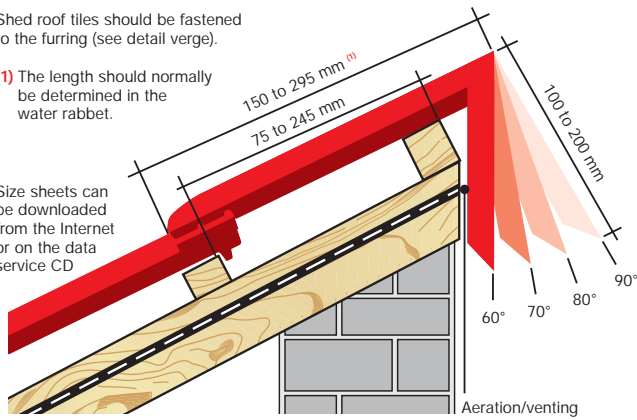

90°

- longest size 295 mm results in a mean lath size 245 mm
- shortest size 150 mm results in a mean lath size 100 mm
- 80° = RP 10°
 - longest size 290 mm results in a mean lath size 230 mm
 - shortest size 150 mm results in a mean lath size 90 mm
- 70° = RP 20°
 - longest size 280 mm results in a mean lath size 215 mm
 - shortest size 150 mm results in a mean lath size 85 mm
- 60° = RP 30°
 - longest size 265 mm results in a mean lath size 190 mm
 - shortest size 150 mm results in a mean lath size 75 mm

Mansard and pent roof tile



Size sheets can be downloaded from the Internet or on the data service CD

Storm clips

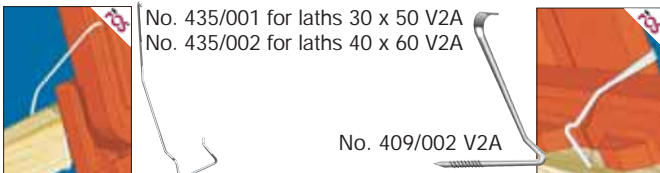

No. 435/001 for laths 30 x 50 V2A
No. 435/002 for laths 40 x 60 V2A

No. 409/002 V2A

According to professional standards, we can supply storm clips for a simple and effective protection against wind suction. They can alternatively be clipped to the laths or knocked into the laths. Resistant to corrosion through stainless steel wire 1.4301 (A2) or ZIAL® coating (corrosion protection).

Installation instructions for alu base tile with single step/walking grid tile/snow stop tile

Of stainless steel/aluminium. No supporting laths needed!
Fastening to supporting lath: Aluminium tile fastened to lath with 2 screws (V2A screw included)

Processing acc. to DIN 18160-5		
Article	≤ 45°	> 45°
Walking grid tile	every 2 nd row of tiles	every row of tiles
Alu base tile	every row of tiles	every row of tiles
w step tile	every row of tiles	every row of tiles

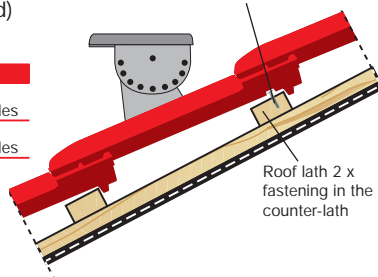

tested to DIN EN 516

The same applies for alu pantiles with snow rib or round wood holder, whereby the max. support spacing should not exceed 90 cm. For higher demands you should reduce the support spacing (60 cm).

Aeration and ventilation in steep roof

- 1 Eaves fresh air element
- 2 Copper roll/Alu roll 2000
- 3 Clay dormer ventilator with fitted screen vent cross-section ~ 15 cm²

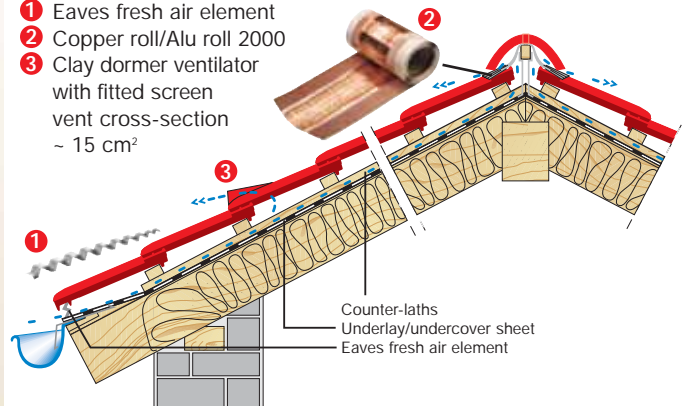

- 1) The vent cross-section at the eaves should be at least 200 cm²/m of eaves.
- 2) The vent cross-section at the ridge or crest should be at least 0.5% of the total corresponding roof area, though at least 50 cm².
(according to DIN 4108-3)

Laying instructions for ridge connecting tile

Max. range of movement 8.0 cm

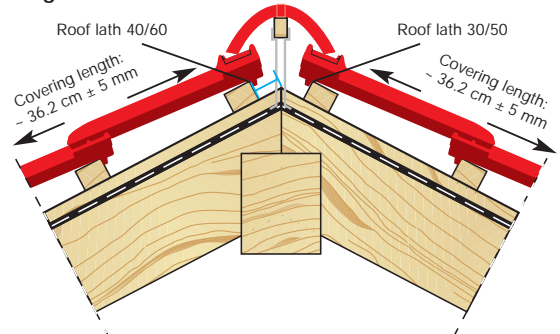

Ridge design with ridge connecting tiles

Upper edge 1st lath from ridge crown

up to 30° RP	Laths 30 x 50 mm	5.0 cm
up to 30° RP	Laths 40 x 60 mm	4.0 cm
up to 45° RP	Laths 30 x 50 mm	4.5 cm
up to 45° RP	Laths 40 x 60 mm	3.5 cm
over 50° RP	Laths 30 x 50 mm	4.0 cm
over 50° RP	Laths 40 x 60 mm	3.0 cm

The dimensions are planning figures and should be checked before laying.

Installation instructions for universal alu step

A chase is made in the head and foot interlocking joint of the gutter tile using a right angle grinder with diamond wheel to lead through the stainless steel suspension hinge. Hang the alu mounting bracket in the throat of the gutter tile so that the two rubber profiles with the lower end of the mounting bracket lie on the roof lath. The rubber profiles must rest where the gutter tiles overlap.

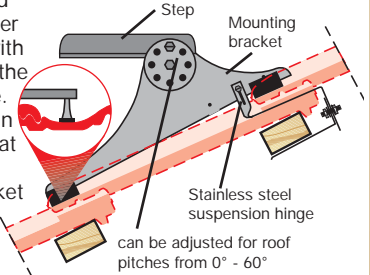

Installation instructions on delivery

tested to
DIN EN 516

On the NELSKAMP data service CD or as a download on the Internet from www.nelskamp.de

- Product specifications
- Laying instructions
- CAD data

DOWNLOAD



For colourful, clean roofs. The Nelskamp concrete roofing tile program.

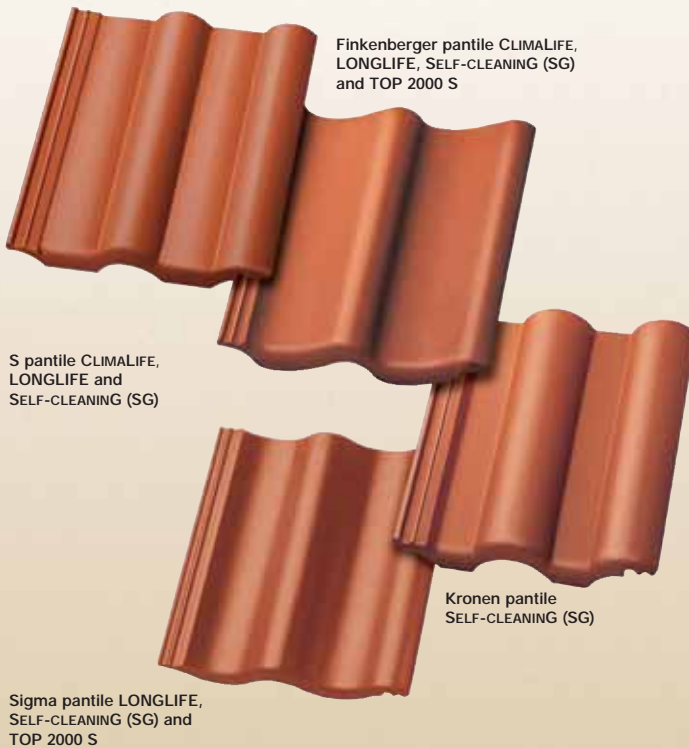

CLIMALIFE concrete roofing tiles

With their ClimaLife surface our roof pantiles clean our environment from contaminants resulting from heating, traffic and the industry. Up to 90 percent are neutralized in daylight, without sunlight up to 70 percent. This is due to the titanium oxide content in the micro concrete. It mainly converts nitrogen oxides (NO_x) into harmless substances like NO₃⁻. Again and again, because titanium oxide is a catalyst, which is never used up. The rain does the rest: It just flushes away the substances, which then are harmless.

LONGLIFE concrete roofing tiles

The leading technology of LONGLIFE concrete roofing tiles is based on the smooth surface of micro-concrete and a newly developed, silk-gloss colour coating. Both factors ensure clean roofs with long-lasting, intensive colours. The reason: dirt is washed off by rain and moss or algae find almost no base for growth.

SELF-CLEANING (SG) concrete roofing tiles

SG = Self-cleaninG concrete roofing tiles are also supplied with the newly developed colour coating. Moss and algae find almost no base for growth on the surface.

TOP 2000 S concrete roofing tiles

High-quality raw materials, the latest production methods and established coating technologies with numerous standard and special colours are characteristic of TOP 2000 S concrete roofing tiles.



Concrete roofing tiles and clay roof tiles from Nelskamp. The obvious solution.

Our strategically placed production facilities guarantee that our roof building materials are always well received. Six plants throughout Germany are the sound, logistical basis for co-operation and help spare the environment.

Administration and sales

Waldweg 6 · D-46514 Schermbeck
Postfach 11 20 · D-46510 Schermbeck
Phone: +49 28 53/91 30-0
Fax: +49 28 53/37 59
Email: vertrieb@nelskamp.de
Internet: www.nelskamp.de

Production of concrete roofing tiles

Gartrop Works
Gahlener Straße 158
D-46569 Hünxe-Gartrop
Phone: +49 28 53/91 30-31/32
Fax: +49 28 53/45 59

Dieburg Works
Lagerstraße 30
D-64807 Dieburg
Phone: +49 60 71/98 64-0
Fax: +49 60 71/16 73

Schönerlinde Works
Schönerlinder Bahnhofstraße 6
D-16348 Wandlitz
Phone: +49 30/94 03 91-0
Fax: +49 30/94 12 20 4

Production of clay roof tiles

Schermbeck Works
Waldweg 6
D-46514 Schermbeck
Phone: +49 28 53/91 30-23/17
Fax: +49 28 53/26 70

Unsleben Works
Wechterswinkler Straße 23
D-97618 Unsleben
Phone: +49 97 73/9 10 10
Fax: +49 97 73/7 49

Groß-Ammensleben Works
Magdeburger Straße 42
D-39326 Groß-Ammensleben
Phone: +49 3 92 02/88-6
Fax: +49 3 92 02/88 80 2

From clay. From concrete. From experience.

NELSKAMP