

From clay. From concrete. From experience.

**NELSKAMP**

**NIBRA® flat tile G 10**



**Nibra®**



# The NIBRA® flat tile G 10.



With its symmetrical form and smooth surface, the G 10 flat tile adapts traditional roofing with a new, consistent design. Laid in a simple or pattern roof cladding, the G 10 produces a unique roofing architecture. The easy, economical laying is another advantage of this tile.

#### The G 10 in detail:

- Pressed roof tile according to DIN/EN 1304 with far better quality requirements than required
- Twin head and side trough
- Waterproof, frost-resistant, breathable
- Regular roof pitch 25°
- Requirement per m<sup>2</sup> approx. 10 pcs.



NIBRA® tiles are manufactured from Westerwald clay in a ceramic quality. The correspondingly low water absorption of below 3 % and extreme resistance to frost are preconditions for the long life of NIBRA® tiles.



# The Colours.



(01) natural red



(02) red engobed



(25) dark grey engobed



(29) bright metallic noble engobed



(32) old black engobed



(36) zinc grey noble engobed (glazed)

















**Colour deviations:** Our clay roof tiles are environment-friendly building materials. When using natural raw materials you may experience colour deviations. This is often the case with naturally red tiles since the fired colour is the sole result of natural raw materials with no added metal oxides to change the colour. Deviations are possible in the colours for reasons of printing methods.

**Clay roof tile surfaces:** Minor impairments to the surface are possible due to transport. This does not affect the quality of the tiles.

# The program.

Moulded bricks for various functions meet the demand for homogeneous, architecturally demanding roofs. They are also an important safety factor. Moulded bricks and accessories reduce the amount of laying work and

facilitate calculations. You will find the complete program for every tile on our Internet website [www.nelskamp.de](http://www.nelskamp.de).

|  |  |   |
|--|--|---|
|    | <b>Whole tile (also available with nail hole as required*)</b><br>Length: ~ 48.2 cm<br>Width: ~ 29.3 cm<br>Weight: ~ 4.4 kg                      | Covering length: ~ 39.1 cm ± 10 mm<br>Covering width: ~ 25.0 cm<br>Requirement: ~ 10.0 pcs/m <sup>2</sup> |
|    | <b>Half tile</b><br>Length: ~ 48.2 cm<br>Width: ~ 16.8 cm<br>Weight: ~ 2.5 kg  | Covering length: ~ 39.1 cm ± 10 mm<br>Covering width: ~ 12.5 cm<br>Requirement: individual                |
|    | <b>Double flap</b><br>Length: ~ 48.2 cm<br>Width: ~ 24.5 cm<br>Weight: ~ 3.7 kg  | Covering length: ~ 39.1 cm ± 10 mm<br>Covering width: ~ 24.5 cm<br>Requirement: ~ 2.5 pcs/m               |
|    | <b>Verge tile with outer web on left</b><br>Length: ~ 48.2 cm<br>Width: ~ 22.8 cm<br>Weight: ~ 5.1 kg  | Covering length: ~ 39.1 cm ± 10 mm<br>Covering width: ~ 21.0 cm<br>Requirement: ~ 2.5 pcs/m               |
|    | <b>Verge tile with outer web on right</b><br>Length: ~ 48.2 cm<br>Width: ~ 22.8 cm<br>Weight: ~ 5.1 kg   | Covering length: ~ 39.1 cm ± 10 mm<br>Covering width: ~ 16.5 cm<br>Requirement: ~ 2.5 pcs/m               |
|    | <b>Clay dormer ventilator (ventilation cross-section ~ 20 cm<sup>2</sup>)</b><br>Length: ~ 48.2 cm<br>Width: ~ 29.3 cm<br>Weight: ~ 4.3 kg       | Covering length: ~ 39.1 cm ± 10 mm<br>Covering width: ~ 25.0 cm<br>Requirement: individual                |
|   | <b>Standard ridge tile ~ 2.6 pcs/m</b><br>Length: ~ 43.7 cm<br>Width: ~ 25.4 cm<br>Weight: ~ 3.6 kg  | Covering length: ~ 38.2 cm<br>Covering width: ~ 19.6 cm<br>Requirement: ~ 2.6 pcs/m                       |
|  | <b>Standard start ridge with extended web for verge tile with outer web</b><br>Length: ~ 43.7 cm<br>Width: ~ 25.4 cm                             | Covering length: ~ 38.2 cm<br>Covering width: ~ 19.6 cm   |
|  | <b>Standard ridge end with extended web for verge tile with outer web</b><br>Length: ~ 38.0 cm<br>Width: ~ 25.4 cm                               | Covering length: ~ 36.0 cm<br>Covering width: ~ 19.6 cm   |
|  | <b>Universal hip cap (also available with four outlets)</b><br>Weight: ~ 4.5 kg  | Requirement: individual   |
|  | <b>Standard crest start</b><br>Length: ~ 49.0 cm<br>Width: ~ 22.2 cm<br>Weight: ~ 3.5 kg   | Covering length: ~ 43.9 cm<br>Covering width: ~ 19.8 cm<br>Requirement: individual                        |
|  | <b>Square ridge tile ~ 2.5 pcs/m</b><br>Length: ~ 43.6 cm<br>Width: ~ 25.6 cm<br>Weight: ~ 4.3 kg  | Covering length: ~ 38.0 cm<br>Covering width: ~ 17.3 cm<br>Requirement: ~ 2.5 pcs/m                       |
|  | <b>Square start ridge with extended web for verge tile with outer web</b><br>Length: ~ 43.6 cm<br>Width: ~ 25.6 cm                               | Covering length: ~ 38.7 cm<br>Covering width: ~ 17.3 cm   |
|  | <b>Square ridge end with extended web for verge tile with outer web</b><br>Length: ~ 38.0 cm<br>Width: ~ 25.6 cm                                 | Covering length: ~ 35.6 cm<br>Covering width: ~ 17.3 cm   |
|  | <b>Universal square hip cap (also available with four outlets)</b><br>Weight: ~ 4.5 kg   | Requirement: individual   |
|  | <b>Shed roof tile (left/right verge tiles also available)</b><br>Length: individual<br>Width: ~ 29.3 cm  | Covering length: individual<br>Covering width: ~ 25.0 cm  |
|  | <b>Ceramic vent pipe tile with weather cap ø 150 and matching hose with adapter</b><br>Length: ~ 48.2 cm<br>Width: ~ 29.3 cm<br>Weight: ~ 4.3 kg | Covering length: ~ 39.1 cm ± 10 mm<br>Covering width: ~ 25.0 cm   |



## Ceramic aerial tile

Length: ~ 48.2 cm  
Width: ~ 29.3 cm

Covering length: ~ 39.1 cm ± 10 mm  
Covering width: ~ 25.0 cm



## Ceramic thermal exhaust gas through pantile with universal collar (ø: max. 127 mm) (can be used up a max of 42° RP\*)

Length: ~ 48.2 cm  
Width: ~ 29.3 cm

Covering length: ~ 39.1 cm ± 10 mm  
Covering width: ~ 25.0 cm



## PVC solar carrier tile

Length: ~ 48.2 cm  
Width: ~ 29.3 cm

Covering length: ~ 39.1 cm ± 10 mm  
Covering width: ~ 25.0 cm

Requirement: individual



## Ceramic solar through tile up to ø 70 mm

Length: ~ 48.2 cm  
Width: ~ 29.3 cm

Covering length: ~ 39.1 cm ± 10 mm  
Covering width: ~ 25.0 cm

ø: ≤ 70 mm



## Light tile „Acrylic glass“

Length: ~ 48.2 cm  
Width: ~ 29.3 cm

Covering length: ~ 39.1 cm ± 10 mm  
Covering width: ~ 25.0 cm

Requirement: individual



## 2 Alu-walking grid tile, coated

Width: ~ 34.0 cm  
Length: 40.0; 80.0; 150.0 cm



## SnapStep universal alu step (40 cm and 80 cm universal walking grid with two brackets also available)

coated, for mounting on different lath thicknesses, can be adjusted for roof pitches from 0° - 60°



## Alu base tile with single step

Length: ~ 48.2 cm  
Width: ~ 29.3 cm

Covering length: ~ 39.1 cm ± 10 mm  
Covering width: ~ 25.0 cm

Requirement: individual



## Alu base pantile with twin tube holder

Length: ~ 48.2 cm  
Width: ~ 29.3 cm

Covering length: ~ 39.1 cm ± 10 mm  
Covering width: ~ 25.0 cm

Requirement: individual



## Alu tile with round wood holder (Alu tile with snow rib support also available)

Length: ~ 48.2 cm  
Width: ~ 29.3 cm

Covering length: ~ 39.1 cm ± 10 mm  
Covering width: ~ 25.0 cm



## Steel skylight, coated, 5-tiles, acrylic glazed

(4 whole + 2 half tiles)  
Hatch: 45.0 x 55.0 cm



## Multitherm skylight

Length: ~ 85.0 cm  
Width: ~ 78.0 cm  
Weight: ~ 15.0 kg

Opening: upwards + to the side  
Hatch: 44.0 x 54.0 cm  
Double glazing: ESG Kv 1.4



## Living room skylight wra

Length: ~ 98.0 cm  
Width: ~ 54.0 cm

Opening: to the side  
Hatch: 46.0 x 90.0 cm  
Double glazing: ESG Kv 1.1

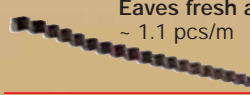

## Eaves fresh air element

~ 1.1 pcs/m

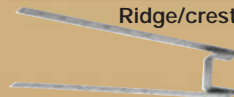

## Ridge/crest lath holder



## Ridge or crest clip no. 470/41 (standard ridge)

Ridge or crest clip no. 470/166 (square ridge)



## Copper roll/Alu roll 2000

Length: ~ 5 m  
Width: ~ 29 cm, 33 cm, 36 cm

Ventilation cross-section: permanent acc. to DIN 4108, Part 3  
Natural copper/anthracite, red



## Storm clip no. 409/008 V2A

# Laying the NIBRA® flat tile G 10.

Type of laying: Row roofing or pattern roof cladding

The optical covering pattern should be agreed with the parties involved in the building before laying.

## Technical data

|                                |                       |
|--------------------------------|-----------------------|
| Roof tile                      | NIBRA® flat tile G 10 |
| Manufacturer                   | Nelskamp (D)          |
| Overall length                 | ~ 48.2 cm             |
| Overall width                  | ~ 29.3 cm             |
| Mean covering length           | ~ 39.1 cm ± 10 mm     |
| Mean covering width            | ~ 25.0 cm             |
| Requirement per m <sup>2</sup> | ~ 10.0 pieces         |
| Weight per tile                | ~ 4.4 kg              |
| Weight per m <sup>2</sup>      | ~ 44.0 kg             |
| Regular roof pitch             | 25°                   |
| Recommended supporting laths   | 40 x 60 mm            |

## Laying!

The following applies when laying our clay roof tiles:

1. The NELSKAMP manufacturer's instructions take priority (laying instructions)
2. The specialist rules of the roofing trade (rules for coverings with clay roof tiles)
3. The German Construction Contract Procedures (VOB) (clay roof tile cover)

## Material requirements for coverage

|  |   |
|--|---|
| Laths                                    | ~ 2.5 m/m <sup>2</sup> (incl. 10% waste)                  |
| Counter-laths                            | ~ 1.7 m/m <sup>2</sup> (incl. 10% waste)                  |
| Roof tile                                | ~ 10.0 pieces/m <sup>2</sup>                              |
| Packing unit*                            |   |
| Tiles per pallet                         | 240 pieces  |
| Tiles per stack                          | 30 pieces   |
| Half tile                                | individual  |
| Double flap                              | ~ 2.5 pieces/m for left side of roof only                 |
| Verge tile                               | ~ 2.5 pieces/m  |
| Ridge or crest tile                      | ~ 2.6 pieces/m  |
| Copper roll/Alu roll 2000 (5 m per roll) | as required   |
| Ridge/crest clip 470/41                  | 1.0 piece per ridge tile standard                         |
| Ridge/crest clip 470/166                 | 1.0 piece per ridge tile square                           |
| Wood screws                              | 1.0 piece per ridge tile d = 4.5 mm<br>Screw depth: 24 mm |
| Ridge or crest initial tile              | 1.0 piece per ridge or crest start                        |
| Ridge end tile                           | 1.0 piece per ridge end                                   |
| Ridge lath holder                        | 1.0 piece per rafter                                      |
| Crest lath holder                        | 1.0 piece/ ~ 70 cm  |
| Eaves fresh air element                  | ~ 1.1 piece/m<br>Fresh air ~ 200 cm <sup>2</sup> /m       |

\* only applies for deliveries in Germany

## Regular roof pitch for clay roof tiles

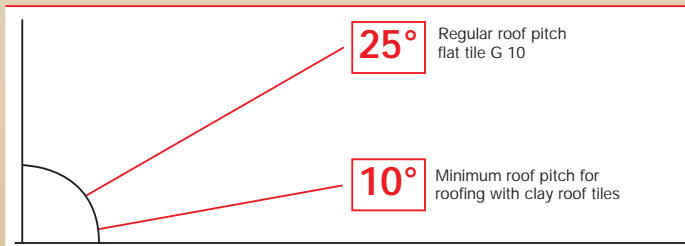

If the pitch is below the regular roof pitch the additional measures of the roofing trade rules must be carried out (cf. table).

With equivalent roof substructure alternatives: pay attention to the manufacturer's and laying instructions. Warranty must be assumed by the relevant manufacturer.

## Classification of additional measures except for subordinate buildings <sup>1)</sup> according to the technical rules of the German roofing trade, last revised January 2010

| Roof pitch | Higher requirements <sup>2)</sup>   |   |  |  |
|------------|---|---|--|--|
|            | Use - Design - Climatic conditions  |   |  |  |
|            | no further increased requirement <sup>2)</sup>  | one further increased requirement <sup>2)</sup>   | two further increased requirement <sup>2)</sup>  | three further increased requirement <sup>2)</sup>  |
| ≥ 25°      | <b>Class 6</b><br>3.3 Underlayment (USB- A) <sup>4)</sup>   | <b>Class 6</b><br>3.3 Underlayment (USB- A) <sup>4)</sup>   | <b>Class 5</b><br>2.4 Overlapping / interlocking undercover (UDB- A; UDB- B <sup>5)</sup> ; USB- A) <sup>4)</sup>  | <b>Class 4</b><br>2.2 Welded / bonded undercover<br>2.3 Undercover covered with bitumen sheeting<br>3.2 Underlayment secured at seams (UDB- A; UDB- B <sup>5)</sup> ; USB- A) <sup>4)</sup>  |
| ≥ 21°      | <b>Class 4</b><br>2.2 Welded / bonded undercover<br>2.3 Undercover covered with bitumen sheeting<br>3.2 Underlayment secured at seams (UDB- A; UDB- B <sup>5)</sup> ; USB- A) <sup>4)</sup> | <b>Class 4</b><br>2.2 Welded / bonded undercover<br>2.3 Undercover covered with bitumen sheeting<br>3.2 Underlayment secured at seams (UDB- A; UDB- B <sup>5)</sup> ; USB- A) <sup>4)</sup> | <b>Class 3</b><br>2.1 Undercover secured at seams and perforations<br>3.1 Underlayment secured at seams and perforations (UDB- A; UDB- B <sup>5)</sup> ; USB- A) <sup>4)</sup> | <b>Class 3</b><br>2.1 Undercover secured at seams and perforations<br>3.1 Underlayment secured at seams and perforations (UDB- A; UDB- B <sup>5)</sup> ; USB- A) <sup>4)</sup>               |
| ≥ 17°      | <b>Class 3</b><br>2.1 Undercover secured at seams and perforations<br>3.1 Underlayment secured at seams and perforations (UDB- A; UDB- B <sup>5)</sup> ; USB- A) <sup>4)</sup>              | <b>Class 3</b><br>2.1 Undercover secured at seams and perforations<br>3.1 Underlayment secured at seams and perforations (UDB- A; UDB- B <sup>5)</sup> ; USB- A) <sup>4)</sup>              | <b>Class 3</b><br>2.1 Undercover secured at seams and perforations<br>3.1 Underlayment secured at seams and perforations (UDB- A; UDB- B <sup>5)</sup> ; USB- A) <sup>4)</sup> | <b>Class 3 <sup>3)</sup></b><br>2.1 Undercover secured at seams and perforations<br>3.1 Underlayment secured at seams and perforations (UDB- A; UDB- B <sup>5)</sup> ; USB- A) <sup>4)</sup> |
| ≥ 13°      | <b>Class 2</b><br>1.2 Rainproof roof substructure   | <b>Class 2</b><br>1.2 Rainproof roof substructure   | <b>Class 1</b><br>1.1 Waterproof roof substructure   | <b>Class 1</b><br>1.1 Waterproof roof substructure   |
| ≥ 10°      | <b>Class 1</b><br>1.1 Waterproof roof substructure  | <b>Class 1</b><br>1.1 Waterproof roof substructure  | <b>Class 1</b><br>1.1 Waterproof roof substructure   | <b>Class 1</b><br>1.1 Waterproof roof substructure   |
| MRP        | 10°   |   |  |  |

<sup>1)</sup> The additional measures named in the table are minimum measures taking into account table 1 of the "Leaflet for roof substructures, undercovers, underlays".

<sup>2)</sup> Higher requirements form categories in accordance with Section 1.1.3. Further higher requirements may result from the weighting within a category according to Section 1.1.3. For example, climatic conditions can lead to several higher requirements.

<sup>3)</sup> Only allowed if proof has been rendered of the functional reliability of the products used including accessories (sealing tapes, adhesive tapes, sealing compounds, ready-made seam protection, etc.) by the manufacturer during a driving rain test. The next highest class should otherwise be chosen.

<sup>4)</sup> Undercover plates are to be assigned according to the classification in the "Leaflet for roof substructures, undercovers and underlays".

<sup>5)</sup> If indices 2), 3), 4), 5) in the product data sheet are met:

2) Resistance to driving rain, proven by the "Driving rain test underlay and undercover sheets - TU Berlin"

3) Higher requirements on ageing are proven by increasing the temperature in the test method Appendix C.5.2 of DIN EN 13859- 1 to 80 °C.

4) The manufacturer specifies the duration of the outdoor weathering period whilst warranting the aforementioned properties.

5) The manufacturer confirms the suitability as a provisional cover and specifies the duration of the outdoor weathering period whilst warranting the aforementioned properties.

## Covering widths

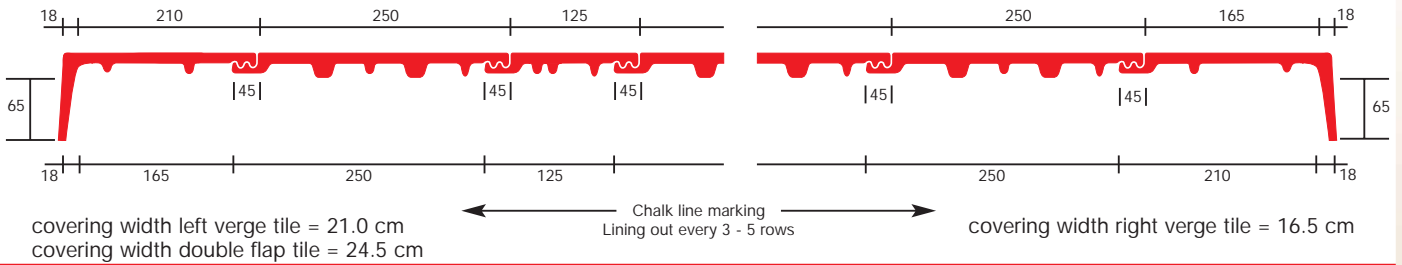

## Roof lathing in conjunction with ridge flaps (dry ridge)

### Supporting laths:

The following min. cross-sections must be used:  
(rules for roofing, notes on wood and timber materials)

| Nom. cross-sections of support laths | Rafter intervals (unit spacing) | Sizing class |
|--------------------------------------|---------------------------------|--------------|
| 30 x 50 mm                           | ≤ 80 cm                         | S 10         |
| 40 x 60 mm                           | ≤ 100 cm                        | S 10         |

### Counter-laths:

Rec. thickness of counter-laths acc. to rules for roofing  
(notes on wood and timber materials):

| Rafter length | Rec. thickness |
|---------------|----------------|
| up to 8 m     | 24 mm          |
| up to 12 m    | 30 mm          |
| over 12 m     | 40 mm          |

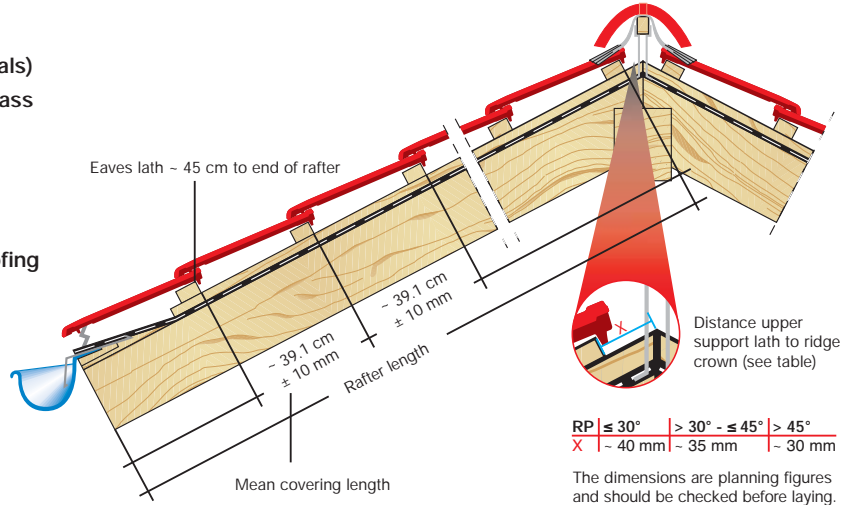

## Details eaves design

The dimensions are planning figures and should be checked before laying depending on the design and local circumstances.

### 1 With gutter & vent element

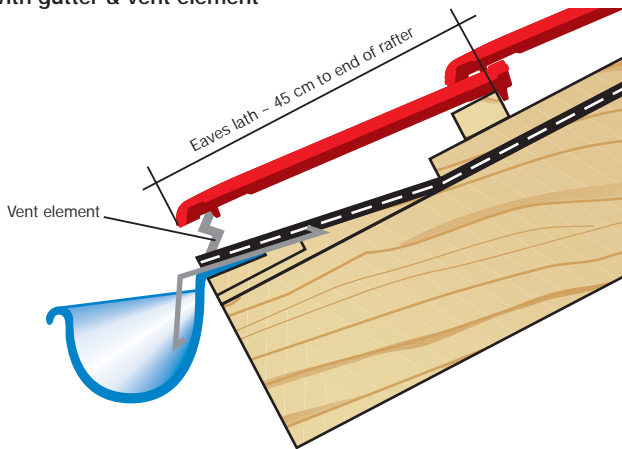

### 2 High-level gutter (recommended for flat roof pitches < 22°)

Tile overhang in gutter max. 1/3 of gutter width

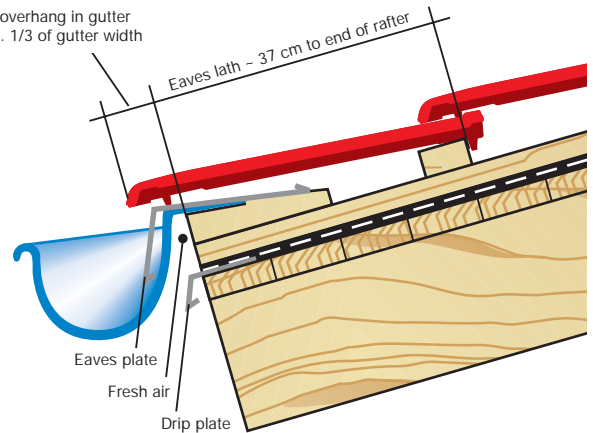

## Ridge/crest details

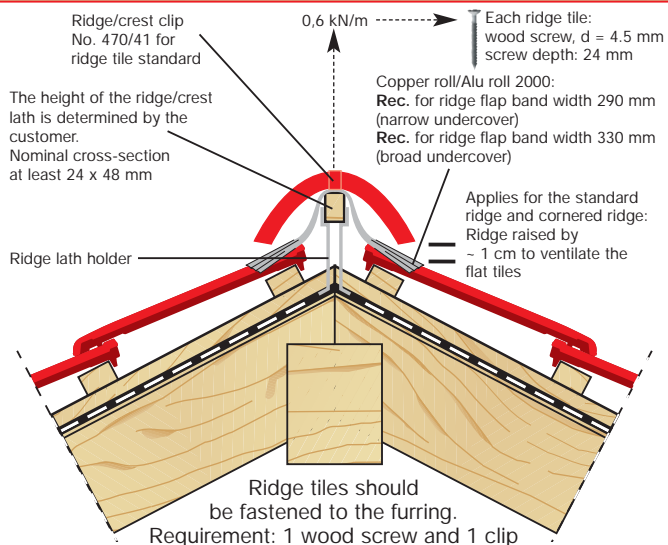

## Verge details

Also applies for the double flap!

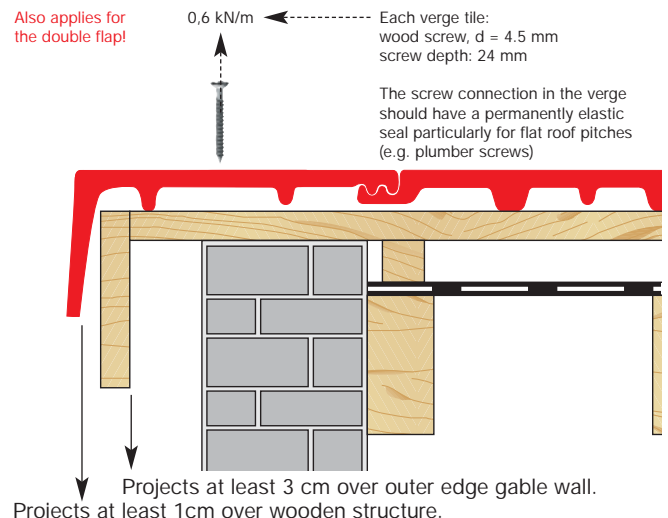

## Shed roof tile

Shed roof tiles should be fastened to the furring (see detail verge).

Size sheets can be downloaded from the Internet or on the data service CD

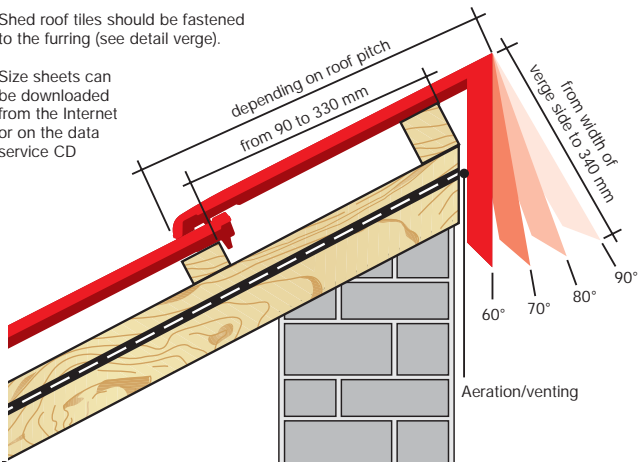

- 90°
  - maximum lath size of 330 mm
  - minimum lath size of 90 mm
- 80° = RP 10°
  - maximum lath size of 310 mm
  - minimum lath size of 90 mm
- 70° = RP 20°
  - maximum lath size of 290 mm
  - minimum lath size of 90 mm
- 60° = RP 30°
  - maximum lath size of 270 mm
  - minimum lath size of 90 mm

## Aeration and ventilation in steep roof

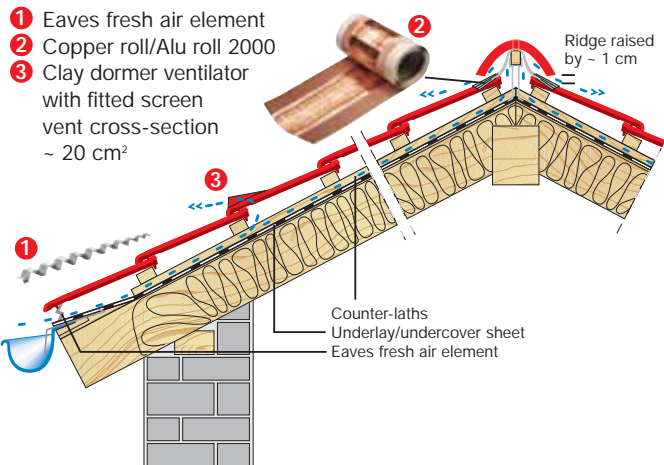

- 1) The vent cross-section at the eaves should be at least 200 cm<sup>2</sup>/m of eaves.
- 2) The vent cross-section at the ridge or crest should be at least 0.5‰ of the total corresponding roof area, though at least 50 cm<sup>2</sup>. (according to DIN 4108-3)

## Installation instructions for alu base tile with single step/walking grid tile/snow stop tile

Of stainless steel/aluminium. No supporting laths needed!  
**Fastening to supporting lath:** Aluminium tile fastened to lath with 2 screws (V2A screw included)

Processing acc. to DIN 18160-5

| Article                   | ≤ 45°              | > 45°              |
|---------------------------|--------------------|--------------------|
| Walking grid tile         | every row of tiles | every row of tiles |
| Alu base tile w step tile | every row of tiles | every row of tiles |

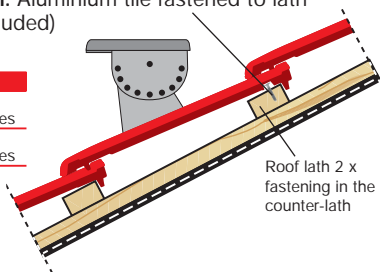

tested to DIN EN 516

The same applies for alu pantiles with snow rib or round wood holder, whereby the max. support spacing should not exceed 90 cm. For higher demands you should reduce the support spacing (60 cm).

## Storm clips

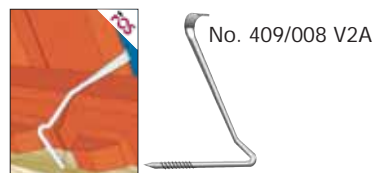

According to professional standards, we can supply storm clips for a simple and effective protection against wind suction. They can alternatively be clipped to the laths or knocked into the laths. Resistant to corrosion through stainless steel wire 1.4301 (A2) or ZIAL® coating (corrosion protection).

## Mansard and pent roof tile

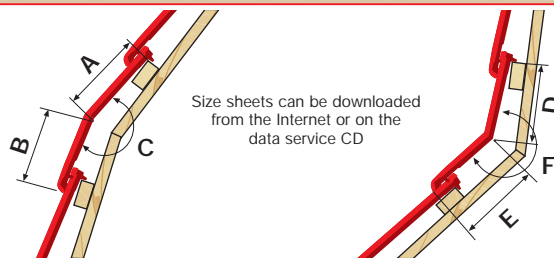

## Installation instructions for universal alu step

A chase is made in the head and foot interlocking joint of the gutter tile using a right angle grinder with diamond wheel to lead through the stainless steel suspension hinge. Hang the alu mounting bracket in the throat of the gutter tile so that the two rubber profiles with the lower end of the mounting bracket lie on the roof lath. The rubber profiles must rest where the gutter tiles overlap.

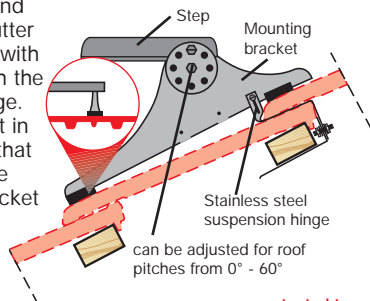

Installation instructions on delivery

tested to DIN EN 516

On the NELSKAMP data service CD or as a download on the Internet from [www.nelskamp.de](http://www.nelskamp.de)

- Product specifications
- Laying instructions
- CAD data

DOWNLOAD



# For colourful, clean roofs. The Nelskamp concrete roofing tile program.

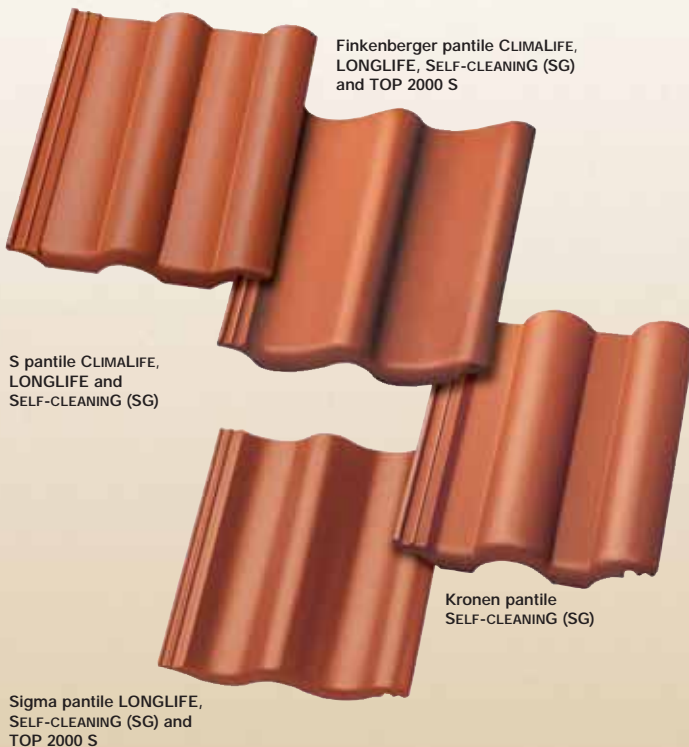

Finkenberger pantile CLIMALIFE,  
LONGLIFE, SELF-CLEANING (SG)  
and TOP 2000 S

S pantile CLIMALIFE,  
LONGLIFE and  
SELF-CLEANING (SG)

Kronen pantile  
SELF-CLEANING (SG)

Sigma pantile LONGLIFE,  
SELF-CLEANING (SG) and  
TOP 2000 S

## CLIMALIFE concrete roofing tiles

With their ClimaLife surface our roof pantiles clean our environment from contaminants resulting from heating, traffic and the industry. Up to 90 percent are neutralized in daylight, without sunlight up to 70 percent. This is due to the titanium oxide content in the micro concrete. It mainly converts nitrogen oxides (NO<sub>x</sub>) into harmless substances like NO<sub>3</sub><sup>-</sup>. Again and again, because titanium oxide is a catalyst, which is never used up. The rain does the rest: It just flushes away the substances, which then are harmless.

## LONGLIFE concrete roofing tiles

The leading technology of LONGLIFE concrete roofing tiles is based on the smooth surface of micro-concrete and a newly developed, silk-gloss colour coating. Both factors ensure clean roofs with long-lasting, intensive colours. The reason: dirt is washed off by rain and moss or algae find almost no base for growth.

## SELF-CLEANING (SG) concrete roofing tiles

SG = Self-cleaninG concrete roofing tiles are also supplied with the newly developed colour coating. Moss and algae find almost no base for growth on the surface.

## TOP 2000 S concrete roofing tiles

High-quality raw materials, the latest production methods and established coating technologies with numerous standard and special colours are characteristic of TOP 2000 S concrete roofing tiles.



## Concrete roofing tiles and clay roof tiles from Nelskamp. The obvious solution.

Our strategically placed production facilities guarantee that our roof building materials are always well received. Six plants throughout Germany are the sound, logistical basis for co-operation and help spare the environment.

### Administration and sales

Waldweg 6 · D-46514 Schermbeck  
Postfach 11 20 · D-46510 Schermbeck  
Phone: +49 28 53/91 30-0  
Fax: +49 28 53/37 59  
Email: [vertrieb@nelskamp.de](mailto:vertrieb@nelskamp.de)  
Internet: [www.nelskamp.de](http://www.nelskamp.de)

### Production of concrete roofing tiles

Gartrop Works  
Gahlener Straße 158  
D-46569 Hünxe-Gartrop  
Phone: +49 28 53/91 30-31/32  
Fax: +49 28 53/45 59

Dieburg Works  
Lagerstraße 30  
D-64807 Dieburg  
Phone: +49 60 71/98 64-0  
Fax: +49 60 71/16 73

Schönerlinde Works  
Schönerlinder Bahnhofstraße 6  
D-16348 Wandlitz  
Phone: +49 30/94 03 91-0  
Fax: +49 30/94 12 20 4

### Production of clay roof tiles

Schermbeck Works  
Waldweg 6  
D-46514 Schermbeck  
Phone: +49 28 53/91 30-23/17  
Fax: +49 28 53/26 70

Unsleben Works  
Wechterswinkler Straße 23  
D-97618 Unsleben  
Phone: +49 97 73/9 10 10  
Fax: +49 97 73/7 49

Groß-Ammensleben Works  
Magdeburger Straße 42  
D-39326 Groß-Ammensleben  
Phone: +49 3 92 02/88-6  
Fax: +49 3 92 02/88 80 2

From clay. From concrete. From experience.

# NELSKAMP