

## Technical data

Roof tile	NIBRA® H 14 hollow interlocking tile
Manufacturer	Nelskamp (D)
Overall length	~ 43.0 cm
Overall width	~ 26.4 cm
Mean covering length	~ 33.2 cm ± 10 mm
Mean covering width	~ 21.3 cm
Requirement per m <sup>2</sup>	~ 13.9 pieces
Weight per tile	~ 3.7 kg
Weight per m <sup>2</sup>	~ 51.4 kg
Regular roof pitch	22°
Laths	30 x 50 mm
Recommended storm clip	435/101*
Laths	40 x 60 mm
Recommended storm clip	435/102*

\*Info: can only be used with a lath spacing of 330 mm or more

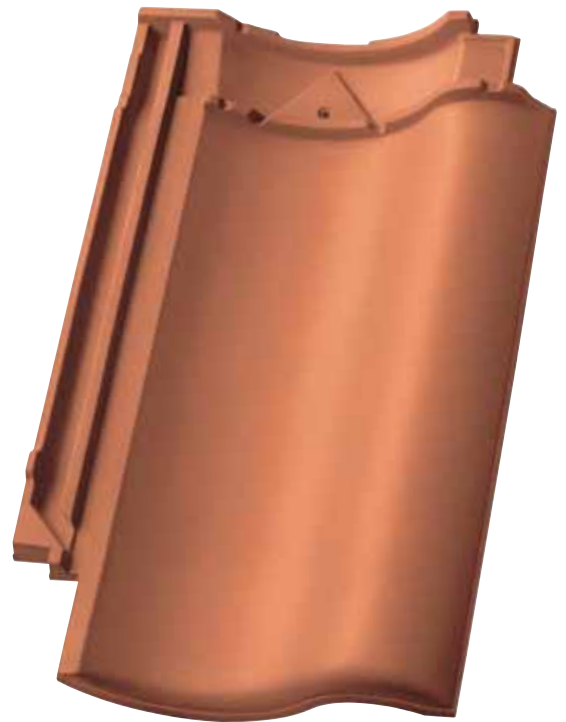

## The Colours

natural red, red engobed, old colours engobed, brown engobed, bordeaux red engobed, black glazed, grass green glazed\* (\*on request), black noble engobed (matt black glazed), blue noble engobed (glazed), pine green noble engobed (glazed), almond brown noble engobed (glazed), steamed\* (\*on request)

## Material requirements for coverage

Laths	~ 3.3 m/m <sup>2</sup> (incl. 10% waste)
Counter-laths	~ 1.7 m/m <sup>2</sup> (incl. 10% waste)
Roof tile	~ 13.9 pieces/m <sup>2</sup>
Packing unit*	
Tiles per pallet	240 pieces
Tiles per stack	30 pieces
Double flap	~ 3.0 pieces/m for left side of roof only
Verge tile	~ 3.0 pieces/m
Safety step pantile	as required
Ridge or crest tile	~ 2.6 pieces/m
Copper roll/Alu roll 2000 (5 m per roll)	as required
Ridge/crest clip 470/41	1.0 piece per ridge tile standard
Wood screws	1.0 piece per ridge tile d = 4.5 mm Screw depth: 24 mm
Ridge or crest initial tile	1.0 piece per ridge or crest start
Ridge end tile	1.0 piece per ridge end
Ridge lath holder	1.0 piece per rafter
Crest lath holder	1.0 piece/ ~ 70 cm
Eaves fresh air element	~ 1.1 piece/m Fresh air ~ 200 cm <sup>2</sup> /m

\* only applies for deliveries in Germany

## Laying!

The following applies when laying our clay roof tiles:

1. The NELSKAMP manufacturer's instructions take priority (laying instructions)
2. The specialist rules of the roofing trade (rules for coverings with clay roof tiles)
3. The German Construction Contract Procedures (VOB) (clay roof tile cover)

## Storm clips

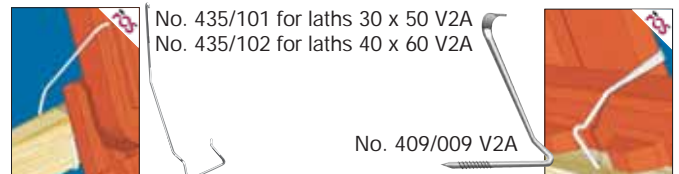

According to professional standards, we can supply storm clips for a simple and effective protection against wind suction. They can alternatively be clipped to the laths or knocked into the laths. Resistant to corrosion through stainless steel wire 1.4301 (A2) or ZIAL® coating (corrosion protection).

## Covering widths

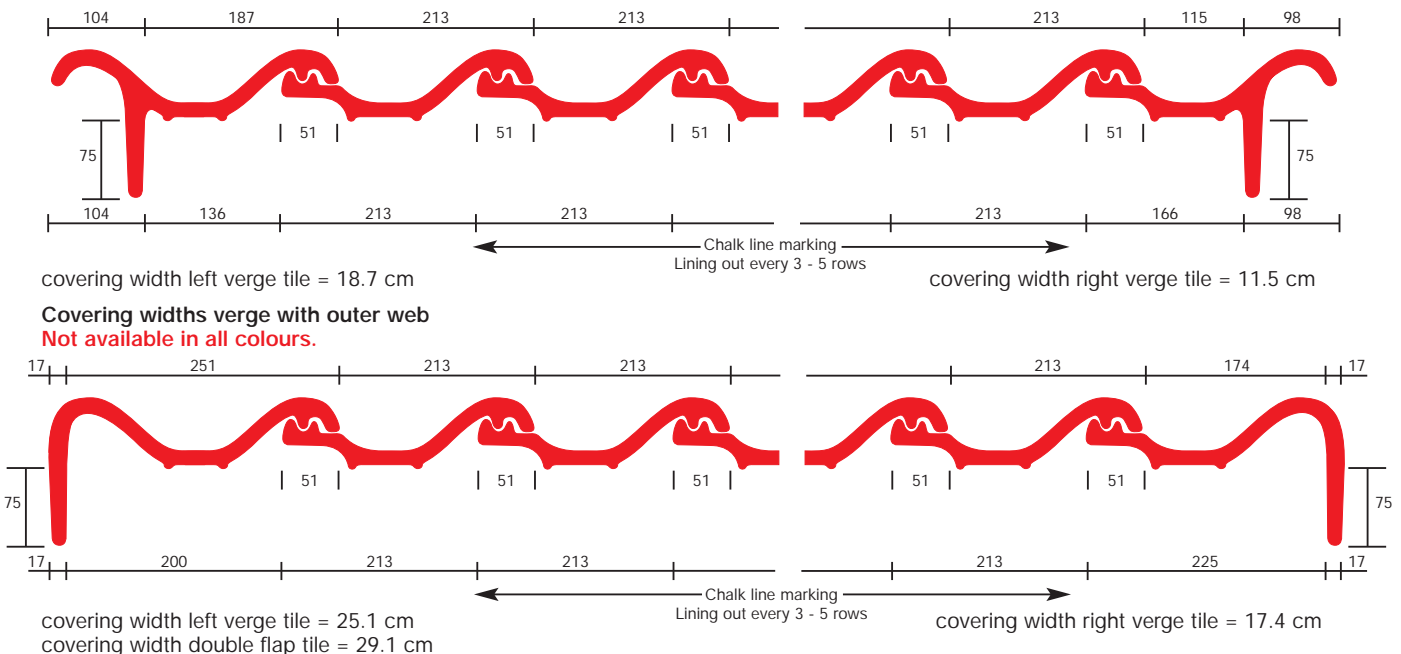

**Classification of additional measures except for subordinate buildings <sup>1)</sup> according to the technical rules of the German roofing trade, last revised January 2010**

Roof pitch	Higher requirements <sup>2)</sup>			
	Use - Design - Climatic conditions			
	no further increased requirement <sup>2)</sup>	one further increased requirement <sup>2)</sup>	two further increased requirement <sup>2)</sup>	three further increased requirement <sup>2)</sup>
≥ 22°	<b>Class 6</b> 3.3 Underlayment (USB- A) <sup>4)</sup>	<b>Class 6</b> 3.3 Underlayment (USB- A) <sup>4)</sup>	<b>Class 5</b> 2.4 Overlapping / interlocking undercover (UDB- A; UDB- B <sup>5)</sup> ; USB- A) <sup>4)</sup>	<b>Class 4</b> 2.2 Welded / bonded undercover 2.3 Undercover covered with bitumen sheeting 3.2 Underlayment secured at seams (UDB- A; UDB- B <sup>5)</sup> ; USB- A) <sup>4)</sup>
≥ 18°	<b>Class 4</b> 2.2 Welded / bonded undercover 2.3 Undercover covered with bitumen sheeting 3.2 Underlayment secured at seams (UDB- A; UDB- B <sup>5)</sup> ; USB- A) <sup>4)</sup>	<b>Class 4</b> 2.2 Welded / bonded undercover 2.3 Undercover covered with bitumen sheeting 3.2 Underlayment secured at seams (UDB- A; UDB- B <sup>5)</sup> ; USB- A) <sup>4)</sup>	<b>Class 3</b> 2.1 Undercover secured at seams and perforations 3.1 Underlayment secured at seams and perforations (UDB- A; UDB- B <sup>5)</sup> ; USB- A) <sup>4)</sup>	<b>Class 3</b> 2.1 Undercover secured at seams and perforations 3.1 Underlayment secured at seams and perforations (UDB- A; UDB- B <sup>5)</sup> ; USB- A) <sup>4)</sup>
≥ 14°	<b>Class 3</b> 2.1 Undercover secured at seams and perforations 3.1 Underlayment secured at seams and perforations (UDB- A; UDB- B <sup>5)</sup> ; USB- A) <sup>4)</sup>	<b>Class 3</b> 2.1 Undercover secured at seams and perforations 3.1 Underlayment secured at seams and perforations (UDB- A; UDB- B <sup>5)</sup> ; USB- A) <sup>4)</sup>	<b>Class 3</b> 2.1 Undercover secured at seams and perforations 3.1 Underlayment secured at seams and perforations (UDB- A; UDB- B <sup>5)</sup> ; USB- A) <sup>4)</sup>	<b>Class 3 <sup>3)</sup></b> 2.1 Undercover secured at seams and perforations 3.1 Underlayment secured at seams and perforations (UDB- A; UDB- B <sup>5)</sup> ; USB- A) <sup>4)</sup>
≥ 10°	<b>Class 2</b> 1.2 Rainproof roof substructure	<b>Class 2</b> 1.2 Rainproof roof substructure	<b>Class 1</b> 1.1 Waterproof roof substructure	<b>Class 1</b> 1.1 Waterproof roof substructure
MRP			10°	

- 1) The additional measures named in the table are minimum measures taking into account table 1 of the "Leaflet for roof substructures, undercovers, underlays".
- 2) Higher requirements form categories in accordance with Section 1.1.3. Further higher requirements may result from the weighting within a category according to Section 1.1.3. For example, climatic conditions can lead to several higher requirements.
- 3) Only allowed if proof has been rendered of the functional reliability of the products used including accessories (sealing tapes, adhesive tapes, sealing compounds, ready-made seam protection, etc.) by the manufacturer during a driving rain test. The next highest class should otherwise be chosen.
- 4) Undercover plates are to be assigned according to the classification in the "Leaflet for roof substructures, undercovers and underlays".
- 5) If indices 2), 3), 4), 5) in the product data sheet are met:
  - 2) Resistance to driving rain, proven by the "Driving rain test underlay and undercover sheets - TU Berlin"
  - 3) Higher requirements on ageing are proven by increasing the temperature in the test method Appendix C 5.2 of DIN EN 13859- 1 to 80 °C.
  - 4) The manufacturer specifies the duration of the outdoor weathering period whilst warranting the aforementioned properties.
  - 5) The manufacturer confirms the suitability as a provisional cover and specifies the duration of the outdoor weathering period whilst warranting the aforementioned properties.

**Roof lathing in conjunction with ridge flaps (dry ridge)**

**Supporting laths:**

The following min. cross-sections must be used:  
(rules for roofing, notes on wood and timber materials)

Nom. cross-sections of support laths	Rafter intervals (unit spacing)	Sizing class
30 x 50 mm	≤ 80 cm	S 10
40 x 60 mm	≤ 100 cm	S 10

**Counter-laths:**

Rec. thickness of counter-laths acc. to rules for roofing  
(notes on wood and timber materials):

Rafter length	Rec. thickness
up to 8 m	24 mm
up to 12 m	30 mm
over 12 m	40 mm

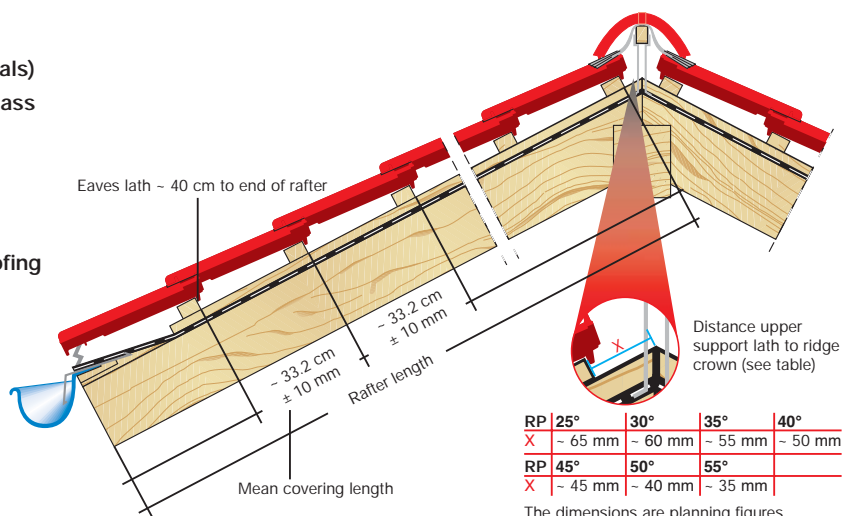

The dimensions are planning figures and should be checked before laying.

**Details eaves design**

The dimensions are planning figures and should be checked before laying depending on the design and local circumstances.

**1 With gutter & vent element**

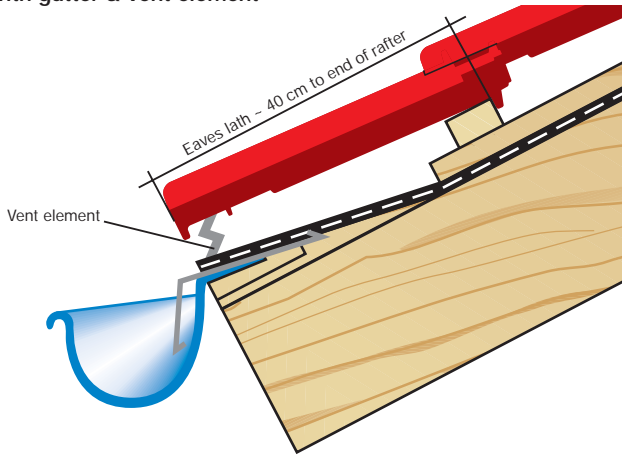

**2 High-level gutter (recommended for flat roof pitches < 22°)**

Tile overhang in gutter max. 1/3 of gutter width

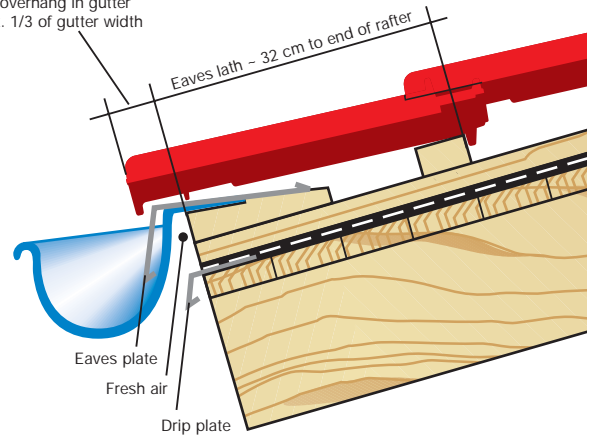

**Ridge/crest details**

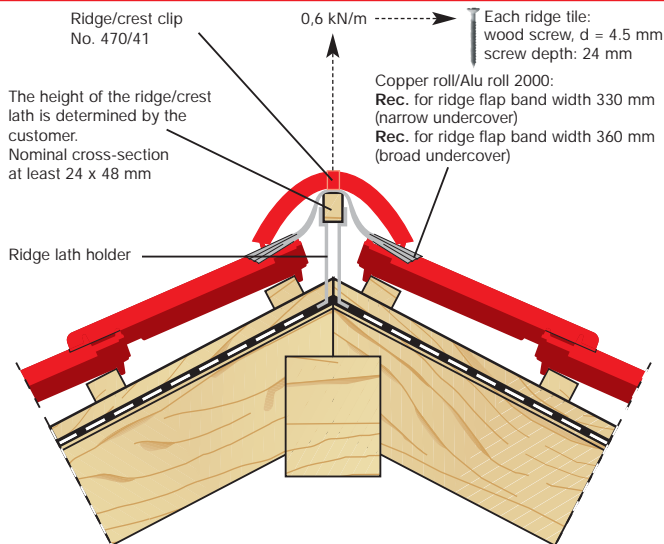

Ridge tiles should be fastened to the furring.  
Requirement: 1 wood screw and 1 clip

**Aeration and ventilation in steep roof**

- 1 Eaves fresh air element
- 2 Copper roll/Alu roll 2000
- 3 Clay dormer ventilator with fitted screen vent cross-section ~ 15 cm²

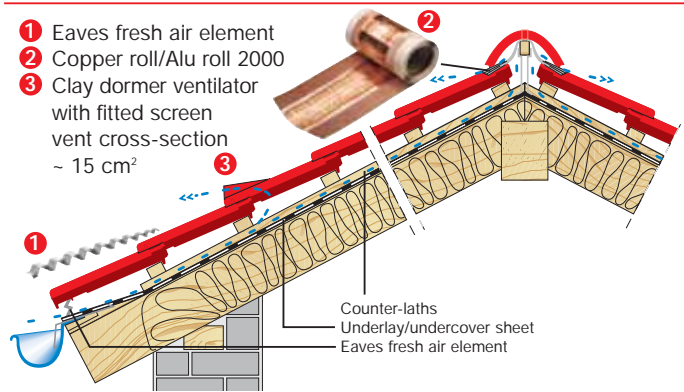

- 1) The vent cross-section at the eaves should be at least 200 cm²/m of eaves.
  - 2) The vent cross-section at the ridge or crest should be at least 0.5‰ of the total corresponding roof area, though at least 50 cm².
- (according to DIN 4108-3)

**Installation instructions for safety step tile/walking grid tile/snow stop tile**

Every safety step tile/walking grid tile must be provided with an additional supporting-safety lath (same lath cross-section as supporting laths). **Fastening to supporting lath:** two corrosion-proof wood screws (4.5 x 45 mm per tile)

Processing acc. to DIN 18160-5		
Article	≤ 45°	> 45°
Walking grid tile	every row of tiles	every row of tiles
Safety step tile	every row of tiles	every row of tiles

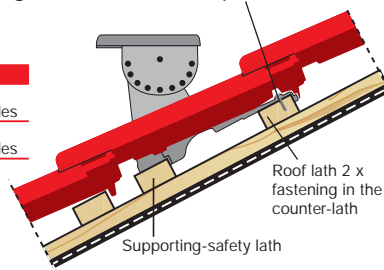

tested to DIN EN 516

The same applies for interlocking tiles with snow rib or round wood holder, whereby the max. support spacing should not exceed 90 cm. For higher demands you should reduce the support spacing (60 cm).

**Installation instructions for universal alu step**

A chase is made in the head and foot interlocking joint of the gutter tile using a right angle grinder with diamond wheel to lead through the stainless steel suspension hinge. Hang the alu mounting bracket in the throat of the gutter tile so that the two rubber profiles with the lower end of the mounting bracket lie on the roof lath. The rubber profiles must rest where the gutter tiles overlap.

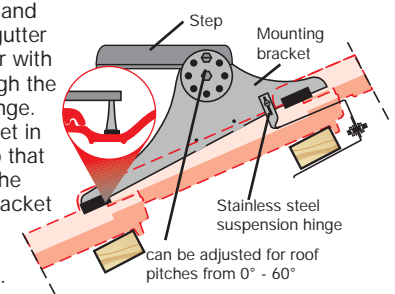

Installation instructions on delivery

tested to DIN EN 516

**Mansard and pent roof tile**

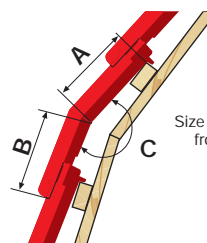

Size sheets can be downloaded from the Internet or on the data service CD



**Laying instructions for ridge connecting tile (with ridge tile extra)**

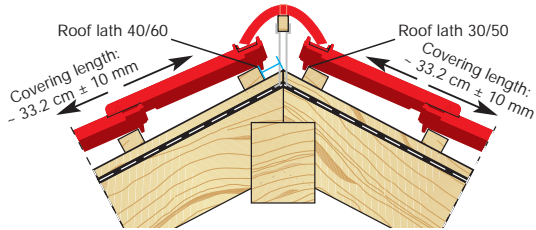

**Ridge design with ridge connecting tiles**

Upper edge 1st lath from ridge crown		
up to 30° RP	Laths 30 x 50 mm	5.0 cm
up to 30° RP	Laths 40 x 60 mm	4.0 cm
up to 45° RP	Laths 30 x 50 mm	4.5 cm
up to 45° RP	Laths 40 x 60 mm	3.5 cm
up to 50° RP	Laths 30 x 50 mm	4.0 cm
up to 50° RP	Laths 40 x 60 mm	3.0 cm

The dimensions are planning figures and should be checked before laying.

**Shed roof tile**

Shed roof tiles should be fastened to the furring (see detail verge).

Size sheets can be downloaded from the Internet or on the data service CD

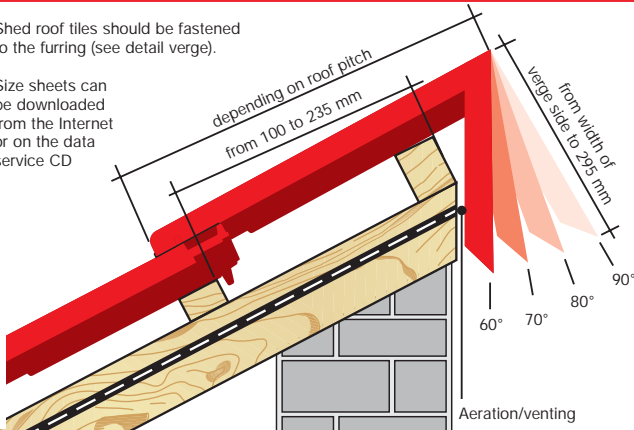

- 90°**
  - maximum lath size of 235 mm
  - minimum lath size of 100 mm
- 80° = RP 10°**
  - maximum lath size of 220 mm
- 70° = RP 20°**
  - minimum lath size of 100 mm
  - maximum lath size of 190 mm
- 60° = RP 30°**
  - minimum lath size of 100 mm
  - maximum lath size of 170 mm

**Verge details**

Also applies for the verge tile with outer web and double flap!

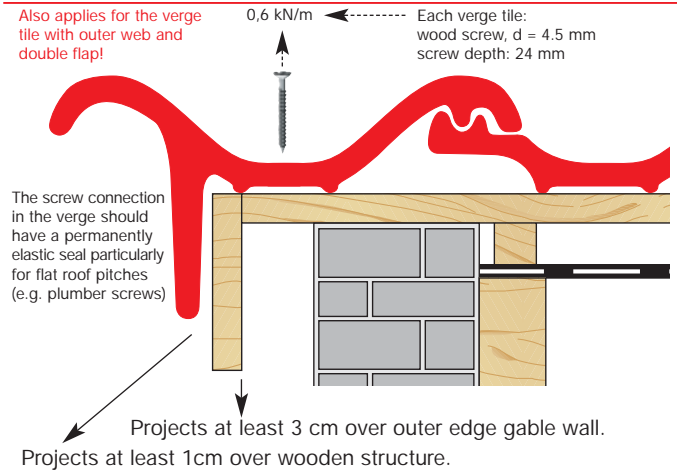

**Ceramic thermal exhaust gas through pantile with universal collar**

Scope of delivery (2-part): Ceramic thermal exhaust gas through pantile with universal collar and large-area tile with cut-out.

Size sheets can be downloaded from the Internet or on the data service CD

