

From clay. From concrete. From experience.

NELSKAMP

Concrete roofing tile program: Kronen pantile



The Kronen pantile.



The characteristic form of the double Roman tile perfectly matches the rounded trimmed edges of the Kronen pantile. This produces uniform and calm roof surfaces.

The Kronen pantile in detail:

- Manufactured according to DIN/EN 490/491 with elevated longitudinal rabbet with far better quality requirements than required
- Overlapping side rabbet and triple base ribbing for optimum protection
- Waterproof, frostproof and resistant to deformation, dimensionally accurate with high compressive strength
- Overlap: approx. 7.5 - 10.6 cm
- Regular roof pitch 22°
- Requirement per m² approx. 10 pcs.

SG = SELF-CLEANING

SG = Self-cleaninG concrete roofing tiles have a new colour coating on which moss and algae have almost no base for growth.



The Colours.

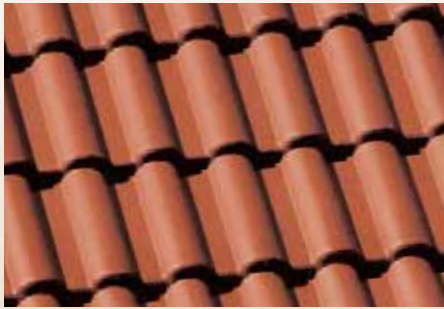

tile red ²⁾



dark brown ²⁾



black ²⁾

²⁾ SELF-CLEANING (SG)

Concrete roofing tile surfaces

	TOP 2000 S	SG = SELF-CLEANING	ONGLIFE
Self-cleaning With the same colour coating, ONGLIFE concrete roofing tiles have advantages over SG concrete roofing tiles due to the smooth, micro-concrete surface.			
Colour fastness SG and ONGLIFE coatings have the highest degradation reserves UV and weathering in terms of colour fastness.			
Abrasion resistance The coating on SG and ONGLIFE concrete roofing tiles is very hard-wearing. These advantages are further optimised by the micro-concrete surface.			
Resistance to growth The results of the self-cleaning have a positive effect on the resistance to the growth of moss and algae.			

Note: The comparative figures for our concrete roofing tile program are based on numerous laboratory tests and, in the meantime, many years of exposure to the elements.





Deviations are possible in the colours for reasons of printing methods.

Concrete roofing tile surfaces: Minor impairments to the surface are possible due to transport. This does not affect the quality of the pantiles.

The program.

Moulded bricks for various functions meet the demand for homogeneous, architecturally demanding roofs. They are also an important safety factor. Moulded bricks and accessories reduce the amount of laying work and

facilitate calculations. You will find the complete program for every concrete roofing tile on our Internet website www.nelskamp.de.

	Complete tile Length: ~ 42.0 cm Width: ~ 34.0 cm Weight: ~ 4.7 kg	Covering length: ~ 31.4 - 34.5 cm* Covering width: ~ 30.0 cm Requirement: ~ 10.0 pcs/m ²
	Half tile Length: ~ 42.0 cm Width: ~ 19.0 cm Weight: ~ 2.8 kg	Covering length: ~ 31.4 - 34.5 cm* Covering width: ~ 15.0 cm Requirement: ~ 3.0 pcs/m
	Double flap Length: ~ 42.0 cm Width: ~ 34.0 cm Weight: ~ 4.9 kg	Covering length: ~ 31.4 - 34.5 cm* Covering width: ~ 34.0 cm Requirement: ~ 3.0 pcs/m
	Left gable tile for 34 or 32 cm laths Length: ~ 42.0 cm Fore-part no. 34 laths: ~ 9.0 cm, no. 32 laths: ~ 11.0 cm Weight: ~ 7.5 kg	Covering width: ~ 31.0 cm Requirement: ~ 3.0 pcs/m
	Right gable tile for 34 or 32 cm laths Length: ~ 42.0 cm Fore-part no. 34 laths: ~ 9.0 cm, no. 32 laths: ~ 11.0 cm Weight: ~ 7.5 kg	Covering width: ~ 27.0 cm Requirement: ~ 3.0 pcs/m
	Ridge/crest tile ~ 2.5 pcs/m Length: ~ 45.0 cm Weight: ~ 4.8 kg	Covering length: ~ 40.0 cm Covering width: ~ 18.5 cm Requirement: 2.5 pcs/m
	Start ridge Length: ~ 45.0 cm Weight: ~ 6.6 kg	Covering length: ~ 38.0 cm Covering width: ~ 18.5 cm Requirement: 1.0 pce/start ridge
	End ridge Length: ~ 45.0 cm Weight: ~ 6.6 kg	Covering length: ~ 43.0 cm Covering width: ~ 18.5 cm Requirement: 1.0 pce/ridge end
	Crest start tile Length: ~ 45.0 cm Weight: ~ 4.7 kg	Covering length: ~ 40.0 cm Covering width: ~ 18.5 cm Requirement: 1.0 pce/crest start
	Hip cap (also available with four outlets) Length: ~ 45.0 cm Weight: ~ 4.8 kg	Requirement: 1.0 pce/hip
	Concrete dormer ventilator (vent cross-section ~ 25 cm²) Length: ~ 42.0 cm Width: ~ 34.0 cm Weight: ~ 5.0 kg	Covering width: ~ 30.0 cm Requirement: individual
	Shed roof tile for counter-laths (left/right verge tiles also available) Length: ~ 42.0 cm Width: ~ 34.0 cm Weight: ~ 5.0 kg	Covering width: ~ 30.0 cm Requirement: 3.3 pcs/m
	Eaves tile for counter-laths (left/right verge tiles also available) Length: ~ 42.0 cm Width: ~ 34.0 cm Weight: ~ 5.0 kg	Covering width: ~ 30.0 cm Requirement: individual
	Mansard tile (left/right verge tiles also available) Length: ~ 42.0 cm Width: ~ 34.0 cm Weight: ~ 5.0 kg	Covering width: ~ 30.0 cm Requirement: individual
	Pent roof tile (left/right verge tiles also available) Length: ~ 42.0 cm Width: ~ 34.0 cm Weight: ~ 5.0 kg	Covering width: ~ 30.0 cm Requirement: individual
	Step tile without support clip Length: ~ 42.0 cm Width: ~ 34.0 cm Weight: ~ 7.4 kg	Covering width: ~ 30.0 cm Requirement: individual
	Step tile with support clip x 2 + walking grid Length: ~ 42.0 cm Width: ~ 34.0 cm Weight: ~ 8.7 kg	Covering width: ~ 30.0 cm Requirement: individual

	Snow stop tile Length: ~ 42.0 cm Width: ~ 34.0 cm Weight: ~ 4.8 kg	Covering width: ~ 30.0 cm Requirement: individual
	Metal-roof plate with round wood holder Length: ~ 42.0 cm Width: ~ 34.0 cm Weight: ~ 5.8 kg	Covering width: ~ 30.0 cm Requirement: individual
	Metal roof plate with snow rib Length: ~ 42.0 cm Width: ~ 34.0 cm Weight: ~ 5.8 kg	Covering width: ~ 30.0 cm Requirement: individual
	PVC solar through pantile Length: ~ 42.0 cm Width: ~ 34.0 cm Weight: ~ 0.6 kg	Covering width: ~ 30.0 cm Requirement: individual ø: 30/50/70 mm
	PVC through pantile with thermal adapter (exhaust gas cap) ø 100 Length: ~ 42.0 cm Width: ~ 34.0 cm Weight: ~ 0.6 kg	Covering width: ~ 30.0 cm Requirement: individual
	PVC thermal exhaust gas through pantile ø 125 (can be used up a max of 40° RP*) Length: ~ 42.0 cm Width: ~ 34.0 cm Weight: ~ 0.6 kg	Covering width: ~ 30.0 cm Requirement: individual
	Klöber through pantile -Venduct- ø 100/125 Length: ~ 42.0 cm Width: ~ 34.0 cm Weight: ~ 1.7 kg	Covering width: ~ 30.0 cm Requirement: individual
	Light pantile „Acrylic glass“ Length: ~ 42.0 cm Width: ~ 34.0 cm Weight: ~ 0.5 kg	Covering width: ~ 30.0 cm Requirement: individual
	Plastic skylight, 4-pantiles, acrylic glazed Length: ~ 77.0 cm Width: ~ 63.5 cm Weight: ~ 3.6 kg	Covering width: ~ 60.0 cm Requirement: individual Hatch: 47.5 x 52.0 cm
	Steel skylight, coated, 4-pantiles, acrylic glazed Length: ~ 78.0 cm Width: ~ 62.5 cm Weight: ~ 9.2 kg	Covering width: ~ 60.0 cm Requirement: individual Hatch: 45.0 x 55.0 cm
	Steel skylight, coated, 6-pantiles, acrylic glazed Length: ~ 108.0 cm Width: ~ 62.5 cm Weight: ~ 11.8 kg	Covering width: ~ 60.0 cm Requirement: individual Hatch: 45.0 x 85.0 cm
	Multitherm skylight Length: ~ 85.0 cm Width: ~ 78.0 cm Weight: ~ 15.0 kg	Opening: upwards + to the side Hatch: 44.0 x 54.0 cm Double glazing: ESG Kv 1.4
	Living room skylight wra Length: ~ 98.0 cm Width: ~ 54.0 cm Weight: ~ 15.0 kg	Opening: to the side Hatch: 46.0 x 90.0 cm Double glazing: ESG Kv 1.1
	Eaves fresh air element ~ 1.1 pcs/m	
	Ridge/crest lath holder	
	Ridge or crest clip no. 470/77	
	Copper roll/Alu roll 2000 Length: ~ 5 m Width: ~ 29 cm, 33 cm, 36 cm Ventilation cross-section: permanent acc. to DIN 4108, Part 3 Natural copper/anthracite, red	
	Storm clip 499/003 (1) Storm clip Nordmark 6 ZIAL® (2)	

Laying the Kronen pantile.

Technical data

Roofing tile	Kronen pantile
Manufacturer	Nelskamp (D)
Overall length	~ 42.0 cm
Overlap	~ 7.5 - 10.6 cm (depending on roof pitch)
Overall width	~ 34.0 cm
Covering width	~ 30.0 cm
Covering length	~ 31.4 - 34.5 cm (depending on roof pitch)
Requirement per m ²	~ 10.0 pieces
Weight per tile	~ 4.7 kg
Weight per m ²	~ 47.0 kg
Regular roof pitch	22°

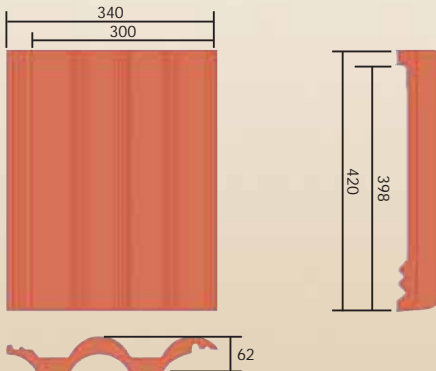

Material requirements for coverage

Laths	~ 3.3 m/m ² (incl. 10% waste)
Counter-laths	~ 1.7 m/m ² (incl. 10% waste)
Roofing tiles	~ 10.0 pieces/m ²
Packing unit*	
Pantiles per stack	34 pieces (packed on pallets on request: 204 pieces per Europallet)
Half tile	as required, ~ 3.0 pcs/m
Double flap	~ 3.0 pieces/m for left side of roof only
Gable tiles for counter-laths	~ 3.0 pieces/m
Step tile with support clip	as required
Step tile with single step	as required
Ridge or crest tile	~ 2.5 pieces/m
Copper roll/Alu roll 2000 (5 m per roll)	as required
Ridge or crest clip 470/77	1.0 piece per ridge tile
Wood screws	1.0 piece per ridge tile d = 4.5 mm Screw depth 24 mm
Ridge or crest disc	1.0 piece per ridge or crest end
Ridge lath holder	1.0 piece per rafter
Crest lath holder	1.0 piece/ ~ 70 cm
Eaves fresh air element	~ 1.1 piece/m Fresh air ~ 200 cm ² /m

* only applies for deliveries in Germany

Laying!

The following applies for laying our concrete roofing tiles:

1. The NELSKAMP manufacturer's instructions take priority (laying instructions)
2. The specialist rules of the roofing trade (rules for coverings with concrete roofing tiles)
3. The Construction Contract Procedures VOB (concrete roofing tiles)

Covering widths

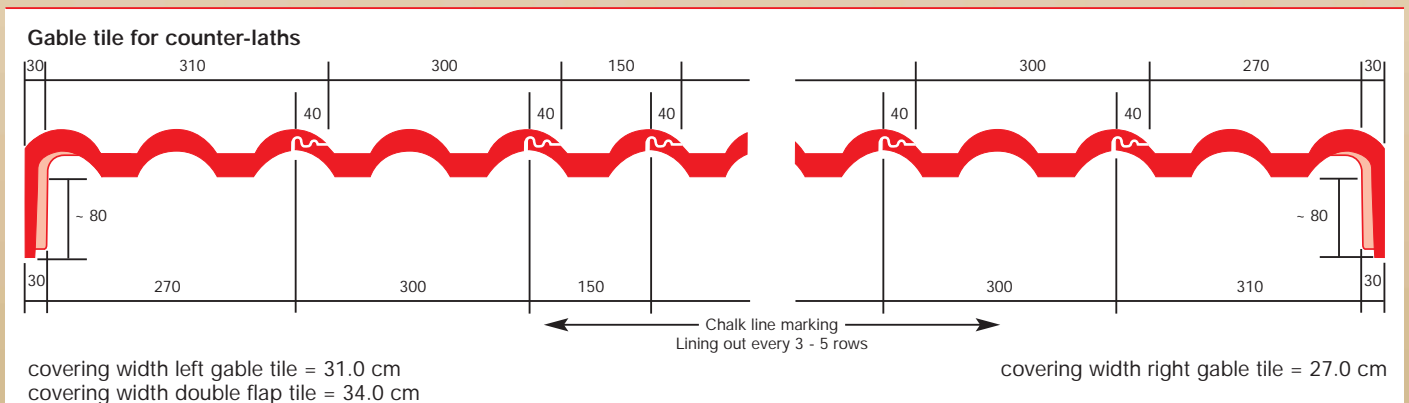

Regular roof pitch for concrete roofing tiles/roof pitch limits

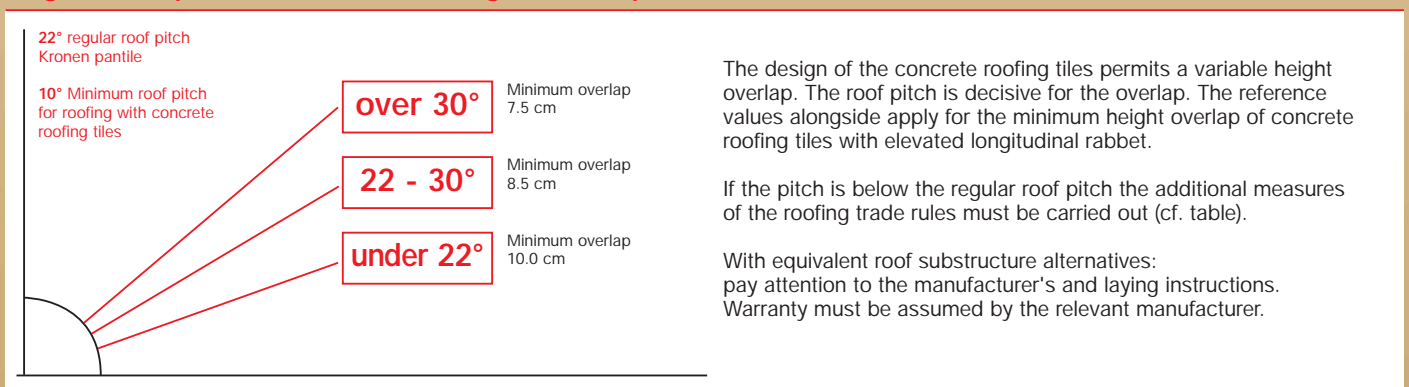

Classification of additional measures except for subordinate buildings ¹⁾ according to the technical rules of the German roofing trade, last revised January 2010

Roof pitch	Higher requirements ²⁾			
	Use - Design - Climatic conditions			
	no further increased requirement ²⁾	one further increased requirement ²⁾	two further increased requirement ²⁾	three further increased requirement ²⁾
≥ 22°	Class 6 3.3 Underlayment (USB- A) ⁴⁾	Class 6 3.3 Underlayment (USB- A) ⁴⁾	Class 5 2.4 Overlapping / interlocking undercover (UDB- A; UDB- B ⁵⁾ ; USB- A) ⁴⁾	Class 4 2.2 Welded / bonded undercover 2.3 Undercover covered with bitumen sheeting 3.2 Underlayment secured at seams (UDB- A; UDB- B ⁵⁾ ; USB- A) ⁴⁾
≥ 18°	Class 4 2.2 Welded / bonded undercover 2.3 Undercover covered with bitumen sheeting 3.2 Underlayment secured at seams (UDB- A; UDB- B ⁵⁾ ; USB- A) ⁴⁾	Class 4 2.2 Welded / bonded undercover 2.3 Undercover covered with bitumen sheeting 3.2 Underlayment secured at seams (UDB- A; UDB- B ⁵⁾ ; USB- A) ⁴⁾	Class 3 2.1 Undercover secured at seams and perforations 3.1 Underlayment secured at seams and perforations (UDB- A; UDB- B ⁵⁾ ; USB- A) ⁴⁾	Class 3 2.1 Undercover secured at seams and perforations 3.1 Underlayment secured at seams and perforations (UDB- A; UDB- B ⁵⁾ ; USB- A) ⁴⁾
≥ 14°	Class 3 2.1 Undercover secured at seams and perforations 3.1 Underlayment secured at seams and perforations (UDB- A; UDB- B ⁵⁾ ; USB- A) ⁴⁾	Class 3 2.1 Undercover secured at seams and perforations 3.1 Underlayment secured at seams and perforations (UDB- A; UDB- B ⁵⁾ ; USB- A) ⁴⁾	Class 3 2.1 Undercover secured at seams and perforations 3.1 Underlayment secured at seams and perforations (UDB- A; UDB- B ⁵⁾ ; USB- A) ⁴⁾	Class 3 ³⁾ 2.1 Undercover secured at seams and perforations 3.1 Underlayment secured at seams and perforations (UDB- A; UDB- B ⁵⁾ ; USB- A) ⁴⁾
≥ 10°	Class 2 1.2 Rainproof roof substructure	Class 2 1.2 Rainproof roof substructure	Class 1 1.1 Waterproof roof substructure	Class 1 1.1 Waterproof roof substructure
MRP	10°			

- The additional measures named in the table are minimum measures taking into account table 1 of the "Leaflet for roof substructures, undercovers, underlays".
- Higher requirements form categories in accordance with Section 1.1.3. Further higher requirements may result from the weighting within a category according to Section 1.1.3. For example, climatic conditions can lead to several higher requirements.
- Only allowed if proof has been rendered of the functional reliability of the products used including accessories (sealing tapes, adhesive tapes, sealing compounds, ready-made seam protection, etc.) by the manufacturer during a driving rain test. The next highest class should otherwise be chosen.
- Undercover plates are to be assigned according to the classification in the "Leaflet for roof substructures, undercovers and underlays".
- If indices 2), 3), 4), 5) in the product data sheet are met:
 - Resistance to driving rain, proven by the "Driving rain test underlay and undercover sheets - TU Berlin"
 - Higher requirements on ageing are proven by increasing the temperature in the test method Appendix C 5.2 of DIN EN 13859- 1 to 80 °C.
 - The manufacturer specifies the duration of the outdoor weathering period whilst warranting the aforementioned properties.
 - The manufacturer confirms the suitability as a provisional cover and specifies the duration of the outdoor weathering period whilst warranting the aforementioned properties.

Roof lathing in conjunction with ridge flaps (dry ridge)

Supporting laths:

The following min. cross-sections must be used:
(rules for roofing, notes on wood and timber materials)

Nom. cross-sections of support laths	Rafter intervals (unit spacing)	Sizing class
30 x 50 mm	≤ 80 cm	S 10
40 x 60 mm	≤ 100 cm	S 10

Counter-laths:

Rec. thickness of counter-laths acc. to rules for roofing
(notes on wood and timber materials):

Rafter length	Rec. thickness
up to 8 m	24 mm
up to 12 m	30 mm
over 12 m	40 mm

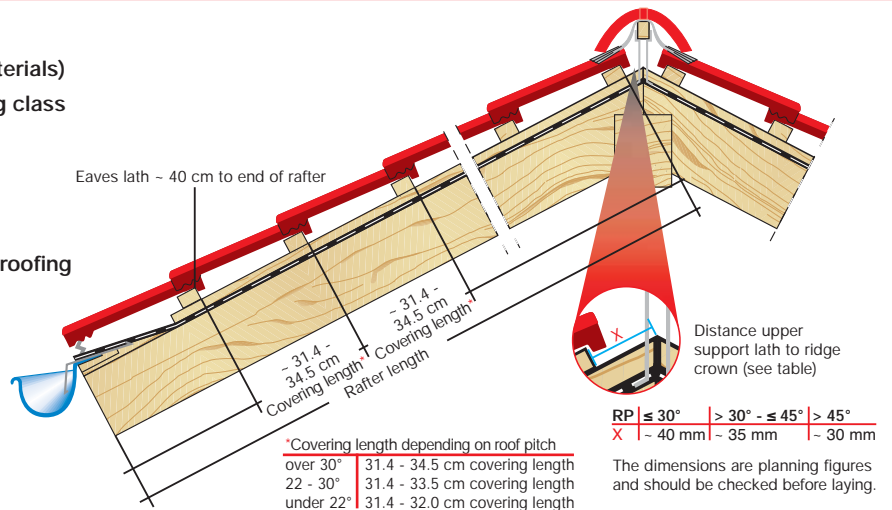

Details eaves design

The dimensions are planning figures and should be checked before laying depending on the design and local circumstances.

1 With gutter & vent element

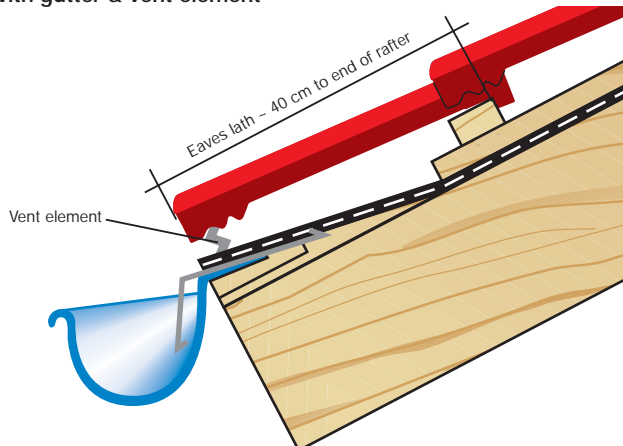

2 High-level gutter (recommended for flat roof pitches < 22°)

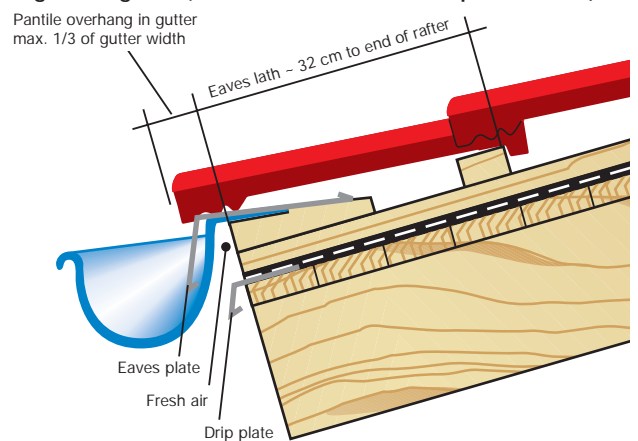

Ridge/crest details

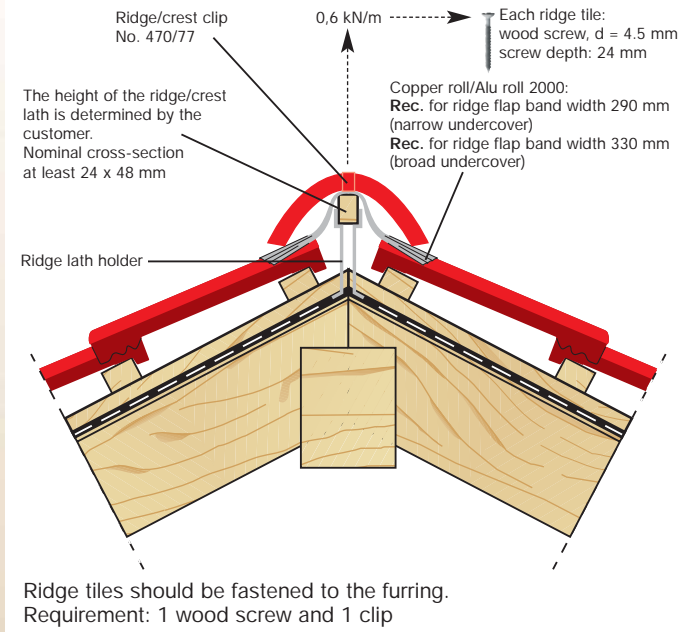

Gable tile details

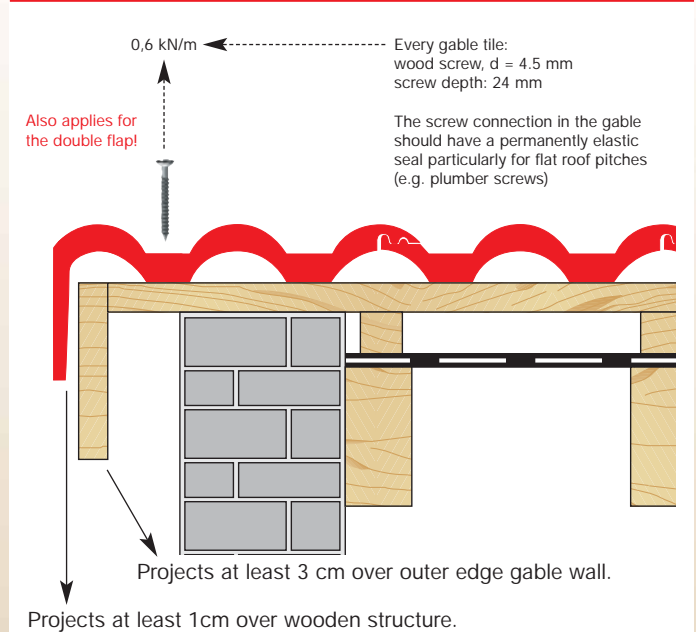

Shed roof tile

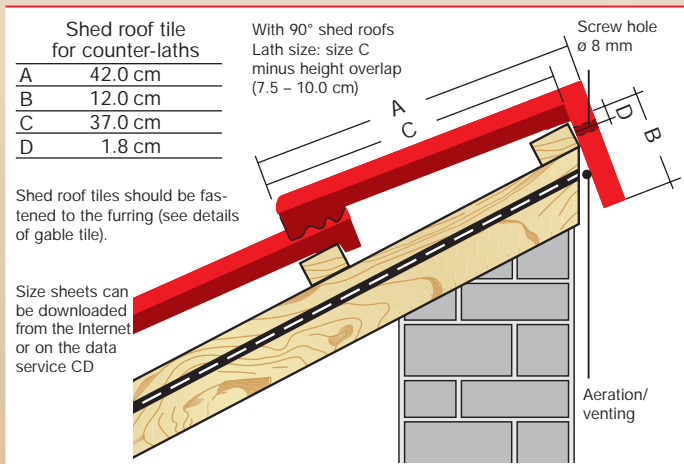

Fore-part gable tile

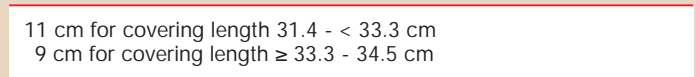

Aeration and ventilation in steep roof

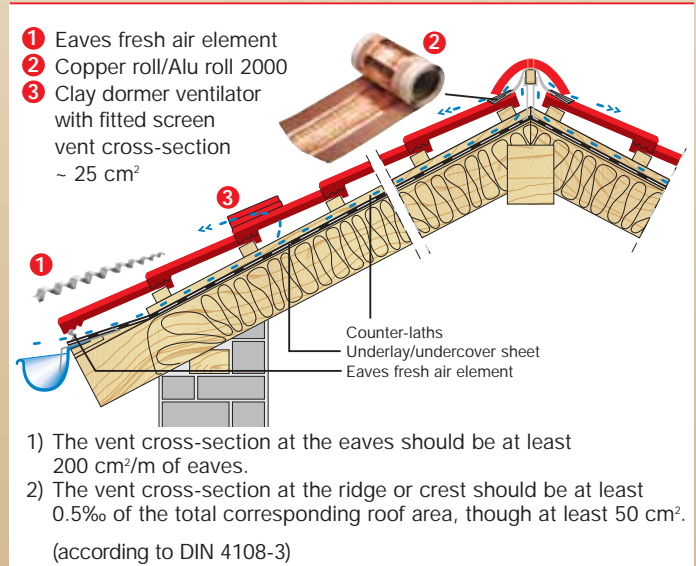

Installation instruction for step tiles with single step/walking grid/snow stop tile

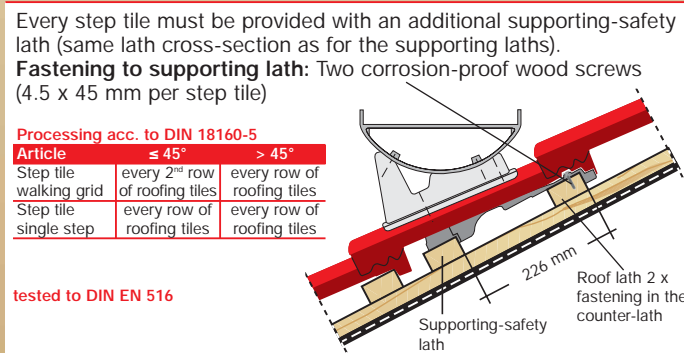

The same applies for metal roof plates with snow ribs or round wood holder, whereby the max. support spacing should not exceed 90 cm. For higher demands you should reduce the support spacing (60 cm).

Storm clips

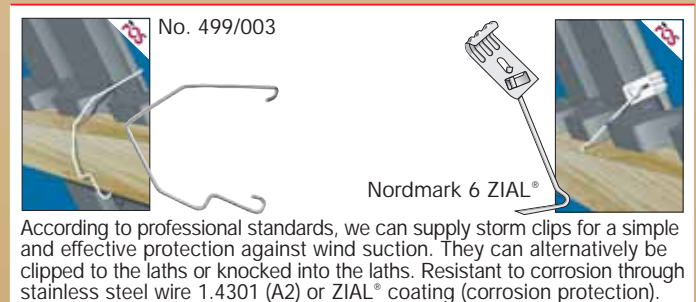

Mansard and pent roof tile

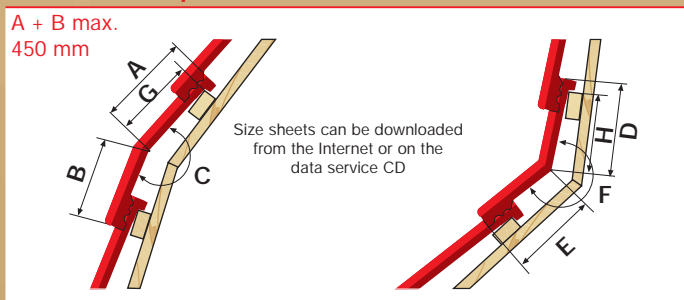

On the NELSKAMP data service CD or as a download on the Internet from www.nelskamp.de

- Product specifications
- Laying instructions
- CAD data

DOWNLOAD



There are two sides to our success. Concrete roofing tiles and clay roof tiles.



Clay roof tiles from Nelskamp have a tradition that goes back for decades and a successful up-to-dateness. There are several stimulations for creative and environment-friendly rooftop architecture. Our program includes not just classical shapes and formats but also new and innovative large-scale developments. The NIBRA® program was the trigger for large-scale, economic roof coverings and new fields of use. For example, the excellent ceramic quality of the tile really comes into its own on hall roofs.



Concrete roofing tiles and clay roof tiles from Nelskamp. The obvious solution.

Our strategically placed production facilities guarantee that our roof building materials are always well received. Six plants throughout Germany are the sound, logistical basis for co-operation and help spare the environment.

Administration and sales

Waldweg 6 · D-46514 Schermbeck
Postfach 11 20 · D-46510 Schermbeck
Phone: +49 28 53/91 30-0
Fax: +49 28 53/37 59
Email: vertrieb@nelskamp.de
Internet: www.nelskamp.de

Production of concrete roofing tiles

Gartrop Works
Gahlener Straße 158
D-46569 Hünxe-Gartrop
Phone: +49 28 53/91 30-31/32
Fax: +49 28 53/45 59

Dieburg Works
Lagerstraße 30
D-64807 Dieburg
Phone: +49 60 71/98 64-0
Fax: +49 60 71/16 73

Schönerlinde Works
Schönerlinder Bahnhofstraße 6
D-16348 Wandlitz
Phone: +49 30/94 03 91-0
Fax: +49 30/94 12 20 4

Production of clay roof tiles

Schermbeck Works
Waldweg 6
D-46514 Schermbeck
Phone: +49 28 53/91 30-23/17
Fax: +49 28 53/26 70

Unsleben Works
Wechterswinkler Straße 23
D-97618 Unsleben
Phone: +49 97 73/9 10 10
Fax: +49 97 73/7 49

Groß-Ammensleben Works
Magdeburger Straße 42
D-39326 Groß-Ammensleben
Phone: +49 3 92 02/88-6
Fax: +49 3 92 02/88 80 2

From clay. From concrete. From experience.

NELSKAMP