

From clay. From concrete. From experience.

NELSKAMP

NIBRA[®] triple trough gutter tile MS 5

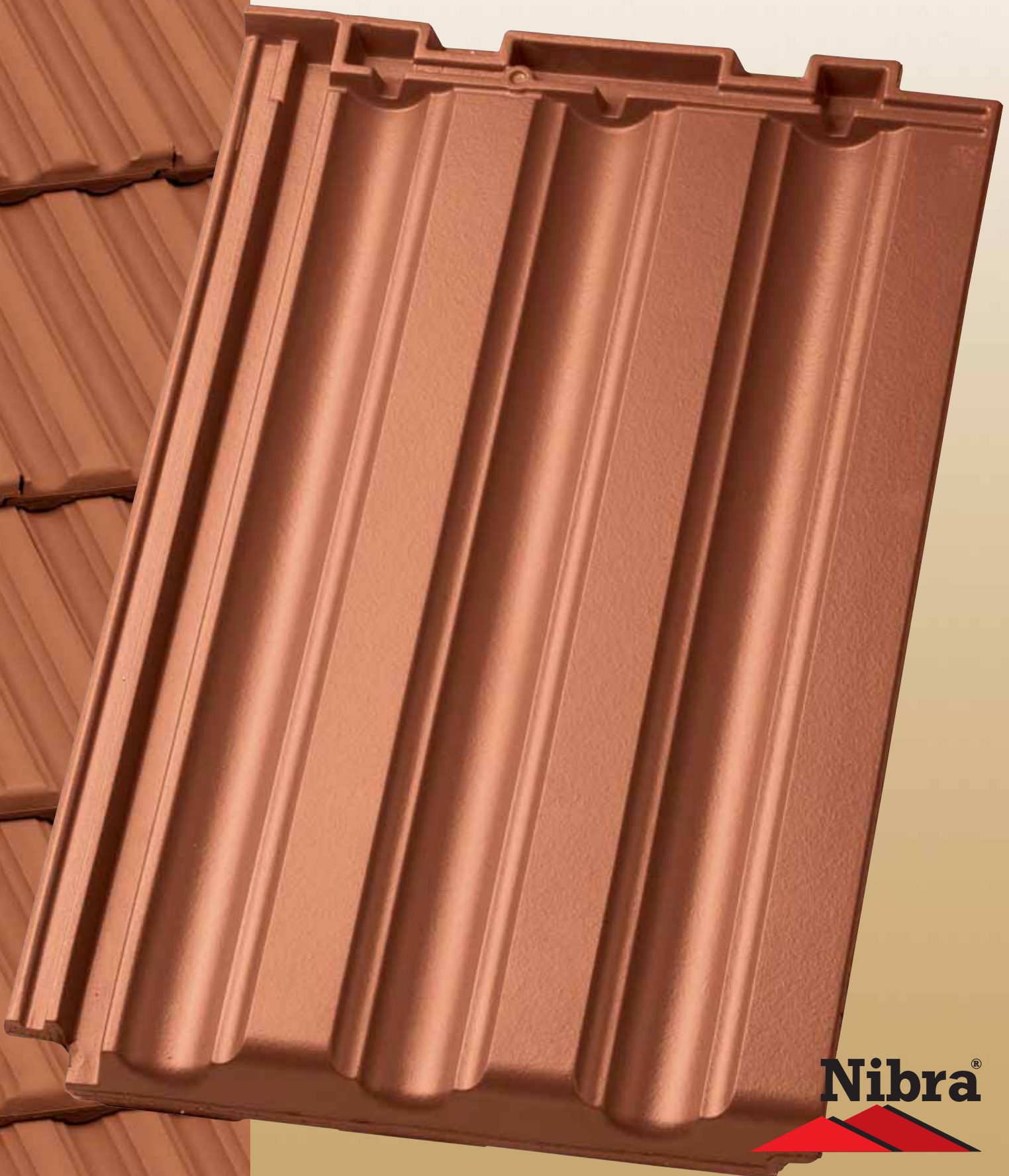

Nibra[®]



NIBRA® triple trough gutter tile MS 5. (sliding tile)



It is modelled on the twin trough gutter tile, a classic on agricultural and historic buildings.

The MS 5 continues the tradition with 3 troughs and as a large-area tile it can be used for both modernising old buildings and halls as well as giving new buildings a characteristic roof design.

The MS 5 is designed as a sliding tile with a range of approx. 10 cm.

This makes laying easier and allows existing roof structures to be used during modernisation work, wherever these can support the tiles.

The MS 5 in detail:

- Pressed roof tile according to DIN/EN 1304/491 with far better quality requirements than required
- Twin head and side trough
- Waterproof, frost-resistant, breathable
- 6.8 kg per tile
- Requirement depending on lath size approx. 6.0 pcs per m²



NIBRA® tiles are manufactured from Westerwald clay in a ceramic quality. The correspondingly low water absorption of below 3 % and extreme resistance to frost are preconditions for the long life of NIBRA® tiles.



The Colours.



(01) natural red



(02) red engobed



(03) old colours engobed

Colour deviations: Our clay roof tiles are environment-friendly building materials. When using natural raw materials you may experience colour deviations. This is often the case with naturally red tiles since the fired colour is the sole result of natural raw materials with no added metal oxides to change the colour. Deviations are possible in the colours for reasons of printing methods.

Clay roof tile surfaces: Minor impairments to the surface are possible due to transport. This does not affect the quality of the tiles.

The program.

Moulded bricks for various functions meet the demand for homogeneous, architecturally demanding roofs. They are also an important safety factor. Moulded bricks and accessories reduce the amount of laying work and

facilitate calculations. You will find the complete program for every tile on our Internet website www.nelskamp.de.

	Whole tile (also available with nail hole as required*) Length: ~ 59.2 cm Covering length: ~ 44.0 - 50.4 cm Width: ~ 37.4 cm Covering width: ~ 33.2 cm Weight: ~ 6.8 kg Requirement: ~ 6.0 pcs/m ²
--	--

	1/3 tile Length: ~ 59.2 cm Covering length: ~ 44.0 - 50.4 cm Width: ~ 15.3 cm Covering width: ~ 11.0 cm Weight: ~ 3.2 kg Requirement: ~ 2.0 pcs/m
--	--

	Sliding verge tile with outer web on left Length: ~ 59.2 cm Covering length: ~ 44.0 - 50.4 cm Width: ~ 13.0 cm Covering width: ~ 11.0 cm Weight: ~ 5.2 kg Requirement: ~ 2.0 pcs/m
--	---

	Sliding verge tile with outer web on right Length: ~ 59.2 cm Covering length: ~ 44.0 - 50.4 cm Width: ~ 13.0 cm Covering width: ~ 6.8 cm Weight: ~ 5.0 kg Requirement: ~ 2.0 pcs/m
--	---

	Standard ridge tile ~ 2.6 pcs/m Length: ~ 43.7 cm Covering length: ~ 38.2 cm Width: ~ 25.4 cm Covering width: ~ 19.6 cm Weight: ~ 3.6 kg Requirement: ~ 2.6 pcs/m
--	--

	Standard start ridge with extended web for verge tile with outer web Length: ~ 43.7 cm Covering length: ~ 38.2 cm Width: ~ 25.4 cm Covering width: ~ 19.6 cm
--	---

	Standard ridge end with extended web for verge tile with outer web Length: ~ 38.0 cm Covering length: ~ 36.0 cm Width: ~ 25.4 cm Covering width: ~ 19.6 cm
---	---

	Standard crest start Length: ~ 49.0 cm Covering length: ~ 43.9 cm Width: ~ 25.4 cm Covering width: ~ 19.6 cm Weight: ~ 3.5 kg Requirement: individual
--	--

	Universal hip cap (also available with four outlets) Weight: ~ 4.5 kg Requirement: individual
--	--

	Universal hip cap with four outlets Weight: ~ 6.3 kg Requirement: individual
--	---

	Clay dormer ventilator (ventilation cross-section ~ 20 cm²) Length: ~ 59.2 cm Covering length: ~ 44.0 - 50.4 cm Width: ~ 37.4 cm Covering width: ~ 33.2 cm Weight: ~ 6.8 kg Requirement: individual
--	---

	Shed roof tile* Length: individual Covering length: individual Width: ~ 37.4 cm Covering width: ~ 33.2 cm
--	--

	Shed roof-verge tile with outer web on left* Length: individual Covering length: individual Width: ~ 13.0 cm Covering width: ~ 11.0 cm
--	---

	Shed roof-verge tile with outer web on right* Length: individual Covering length: individual Width: ~ 13.0 cm Covering width: ~ 6.8 cm
--	---

	Ceramic aerial tile Length: ~ 59.2 cm Covering length: ~ 44.0 - 50.4 cm Width: ~ 37.4 cm Covering width: ~ 33.2 cm Weight: ~ 6.7 kg
--	---

	Ceramic vent pipe tile with weather cap ø 150 and matching hose with adapter Length: ~ 59.2 cm Covering length: ~ 44.0 - 50.4 cm Width: ~ 37.4 cm Covering width: ~ 33.2 cm Requirement: individual
--	---

	Ceramic thermal exhaust gas through pantile with universal collar (ø: max. 127 mm) (can be used up a max of 42° RP*) Length: ~ 59.2 cm Covering length: ~ 44.0 - 50.4 cm Width: ~ 37.4 cm Covering width: ~ 33.2 cm
---	--

	Light pantile „Acrylic glass“ Length: ~ 59.2 cm Covering length: ~ 44.0 - 50.4 cm Width: ~ 37.4 cm Covering width: ~ 33.2 cm Requirement: individual
---	--

	Ceramic solar through tile up to ø 70 mm Length: ~ 59.2 cm Covering length: ~ 44.0 - 50.4 cm Width: ~ 37.4 cm Covering width: ~ 33.2 cm ø: ≤ 70 mm
---	--

	PVC solar carrier pantile Length: ~ 59.2 cm Covering length: ~ 44.0 - 50.4 cm Width: ~ 37.4 cm Covering width: ~ 33.2 cm Requirement: individual
---	--

	2 Alu-walking grid pantile, coated Width: ~ 34.0 cm Length: 40.0; 80.0; 150.0 cm
---	---

	Alu base pantile with single step Length: ~ 59.2 cm Covering length: ~ 44.0 - 50.4 cm Width: ~ 37.4 cm Covering width: ~ 33.2 cm Requirement: individual
---	--

	Alu base pantile with twin tube holder Length: ~ 59.2 cm Covering length: ~ 44.0 - 50.4 cm Width: ~ 37.4 cm Covering width: ~ 33.2 cm Requirement: individual
--	---

	Alu pantile with round wood holder Length: ~ 59.2 cm Covering length: ~ 44.0 - 50.4 cm Width: ~ 37.4 cm Covering width: ~ 33.2 cm Requirement: individual
---	---

	Alu pantile with snow rib support Length: ~ 59.2 cm Covering length: ~ 44.0 - 50.4 cm Width: ~ 37.4 cm Covering width: ~ 33.2 cm Requirement: individual
---	--

	Steel skylight, coated, 4-pantiles, acrylic glazed Length: ~ 91.0 cm Hatch: 45.0 x 85.0 cm Width: ~ 83.0 cm Weight: ~ 10.0 kg
---	--

	Multitherm skylight Length: ~ 85.0 cm Opening: upwards + to the side Width: ~ 78.0 cm Hatch: 44.0 x 54.0 cm Weight: ~ 15.0 kg Double glazing: ESG Kv 1.4
---	---

	Living room skylight wra Length: ~ 98.0 cm Opening: to the side Width: ~ 54.0 cm Hatch: 46.0 x 90.0 cm Double glazing: ESG Kv 1.1
---	---

	Eaves fresh air element ~ 1.1 pcs/m
---	---

	Ridge/crest lath holder
---	--------------------------------

	Ridge or crest clip no. 470/41
---	---------------------------------------

	Copper roll/Alu roll 2000 Length: ~ 5 m Width: ~ 29 cm, 33 cm, 36 cm Ventilation cross-section: permanent acc. to DIN 4108, Part 3 Natural copper/anthracite, red
---	--

	Multi storm claw
---	-------------------------

* Special design

* Over 42° RP = special design of PVC on request

* Delivery period on request

Laying the NIBRA® tile MS 5.

Type of laying: Row roofing or pattern roof cladding

Technical data

Roof tile	NIBRA® tile MS 5
Manufacturer	Nelskamp (D)
Overall length	~ 59.2 cm
Overall width	~ 37.4 cm
Covering length	~ 44.0 - 50.4* cm
Mean covering width	~ 33.2 cm
Requirement per m ²	~ 6.0 pieces (depending on lath size)
Weight per tile	~ 6.8 kg
Weight per m ²	~ 40.8 kg
Regular roof pitch	22°
Recommended storm clip	Multi storm claw

* Possible covering length with fully covered roofs 44.0 - 54.0 cm

Laying!

The following applies when laying our clay roof tiles:

1. The NELSKAMP manufacturer's instructions take priority (laying instructions)
2. The specialist rules of the roofing trade (rules for coverings with clay roof tiles)
3. The German Construction Contract Procedures (VOB) (clay roof tile cover)

Material requirements for coverage

Laths	~ 2.2 m/m ² (incl. 10% waste)
Counter-laths	~ 1.7 m/m ² (incl. 10% waste)
Roof tile	~ 6.0 pieces/m ²
Packing unit*	
Tiles per pallet	120 pieces
Tiles per stack	20 pieces
1/3 tile	individual
Verge tile	~ 2.0 pieces/m
Ridge or crest tile	~ 2.6 pieces/m
Copper roll/Alu roll 2000 (5 m per roll)	as required
Ridge/crest clip 470/41	1.0 piece per ridge tile
Wood screws	1.0 piece per ridge tile d = 4.5 mm Screw depth: 24 mm
Ridge or crest initial tile	1.0 piece per ridge or crest start
Ridge end tile	1.0 piece per ridge end
Ridge lath holder	1.0 piece per rafter
Crest lath holder	1.0 piece/ ~ 70 cm
Eaves fresh air element	~ 1.1 piece/m Fresh air ~ 200 cm ² /m

* only applies for deliveries in Germany



Way of walking

Way of walking during laying. The optimum load point is directly beneath the height overlap.

Regular roof pitch for clay roof tiles

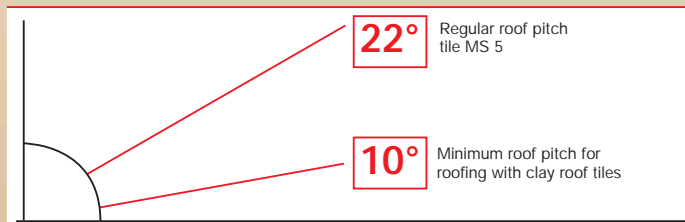

If the pitch is below the regular roof pitch the additional measures of the roofing trade rules must be carried out (cf. table).

With equivalent roof substructure alternatives: pay attention to the manufacturer's and laying instructions. Warranty must be assumed by the relevant manufacturer.

Classification of additional measures except for subordinate buildings ¹⁾ according to the technical rules of the German roofing trade, last revised January 2010

Roof pitch	Higher requirements ²⁾			
	Use - Design - Climatic conditions			
	no further increased requirement ²⁾	one further increased requirement ²⁾	two further increased requirement ²⁾	three further increased requirement ²⁾
≥ 22°	Class 6 3.3 Underlayment (USB- A) ⁴⁾	Class 6 3.3 Underlayment (USB- A) ⁴⁾	Class 5 2.4 Overlapping / interlocking undercover (UDB- A; UDB- B ⁵⁾ ; USB- A) ⁴⁾	Class 4 2.2 Welded / bonded undercover 2.3 Undercover covered with bitumen sheeting 3.2 Underlayment secured at seams (UDB- A; UDB- B ⁵⁾ ; USB- A) ⁴⁾
≥ 18°	Class 4 2.2 Welded / bonded undercover 2.3 Undercover covered with bitumen sheeting 3.2 Underlayment secured at seams (UDB- A; UDB- B ⁵⁾ ; USB- A) ⁴⁾	Class 4 2.2 Welded / bonded undercover 2.3 Undercover covered with bitumen sheeting 3.2 Underlayment secured at seams (UDB- A; UDB- B ⁵⁾ ; USB- A) ⁴⁾	Class 3 2.1 Undercover secured at seams and perforations 3.1 Underlayment secured at seams and perforations (UDB- A; UDB- B ⁵⁾ ; USB- A) ⁴⁾	Class 3 2.1 Undercover secured at seams and perforations 3.1 Underlayment secured at seams and perforations (UDB- A; UDB- B ⁵⁾ ; USB- A) ⁴⁾
≥ 14°	Class 3 2.1 Undercover secured at seams and perforations 3.1 Underlayment secured at seams and perforations (UDB- A; UDB- B ⁵⁾ ; USB- A) ⁴⁾	Class 3 2.1 Undercover secured at seams and perforations 3.1 Underlayment secured at seams and perforations (UDB- A; UDB- B ⁵⁾ ; USB- A) ⁴⁾	Class 3 2.1 Undercover secured at seams and perforations 3.1 Underlayment secured at seams and perforations (UDB- A; UDB- B ⁵⁾ ; USB- A) ⁴⁾	Class 3 ³⁾ 2.1 Undercover secured at seams and perforations 3.1 Underlayment secured at seams and perforations (UDB- A; UDB- B ⁵⁾ ; USB- A) ⁴⁾
≥ 10°	Class 2 1.2 Rainproof roof substructure	Class 2 1.2 Rainproof roof substructure	Class 1 1.1 Waterproof roof substructure	Class 1 1.1 Waterproof roof substructure
MRP			10°	

- 1) The additional measures named in the table are minimum measures taking into account table 1 of the "Leaflet for roof substructures, undercovers, underlays".
- 2) Higher requirements form categories in accordance with Section 1.1.3. Further higher requirements may result from the weighting within a category according to Section 1.1.3. For example, climatic conditions can lead to several higher requirements.
- 3) Only allowed if proof has been rendered of the functional reliability of the products used including accessories (sealing tapes, adhesive tapes, sealing compounds, ready-made seam protection, etc.) by the manufacturer during a driving rain test. The next highest class should otherwise be chosen.
- 4) Undercover plates are to be assigned according to the classification in the "Leaflet for roof substructures, undercovers and underlays".
- 5) If indices 2), 3), 4), 5) in the product data sheet are met:
 - 2) Resistance to driving rain, proven by the "Driving rain test underlay and undercover sheets - TU Berlin"
 - 3) Higher requirements on ageing are proven by increasing the temperature in the test method Appendix C 5.2 of DIN EN 13859- 1 to 80 °C.
 - 4) The manufacturer specifies the duration of the outdoor weathering period whilst warranting the aforementioned properties.
 - 5) The manufacturer confirms the suitability as a provisional cover and specifies the duration of the outdoor weathering period whilst warranting the aforementioned properties.

Covering widths

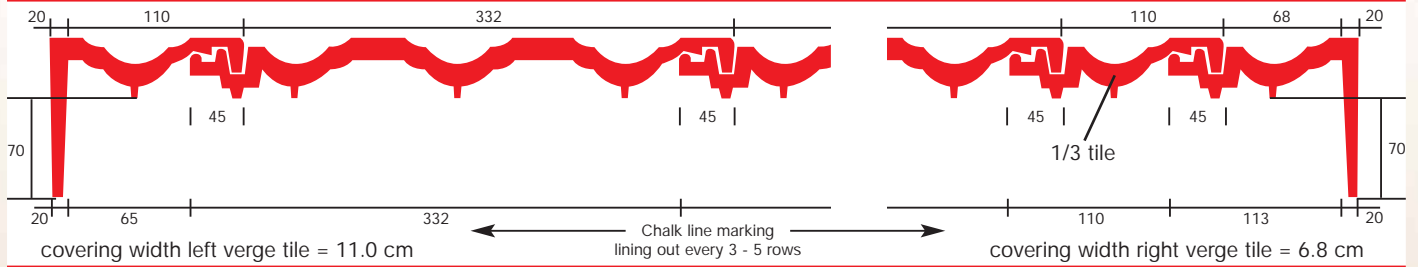

Roof lathing in conjunction with ridge flaps (dry ridge)

Supporting laths:

The following min. cross-sections must be used:
(rules for roofing, notes on wood and timber materials)

Nom. cross-sections of support laths	Rafter intervals (unit spacing)	Sizing class	
30 x 50 mm	≤ 80 cm	S 10	(max. covering length 49.4 cm)
40 x 60 mm	≤ 100 cm	S 10	(max. covering length 50.4 cm)

Counter-laths:

Rec. thickness of counter-laths acc. to rules for roofing
(notes on wood and timber materials):

Rafter length	Rec. thickness
up to 8 m	24 mm
up to 12 m	30 mm
over 12 m	40 mm

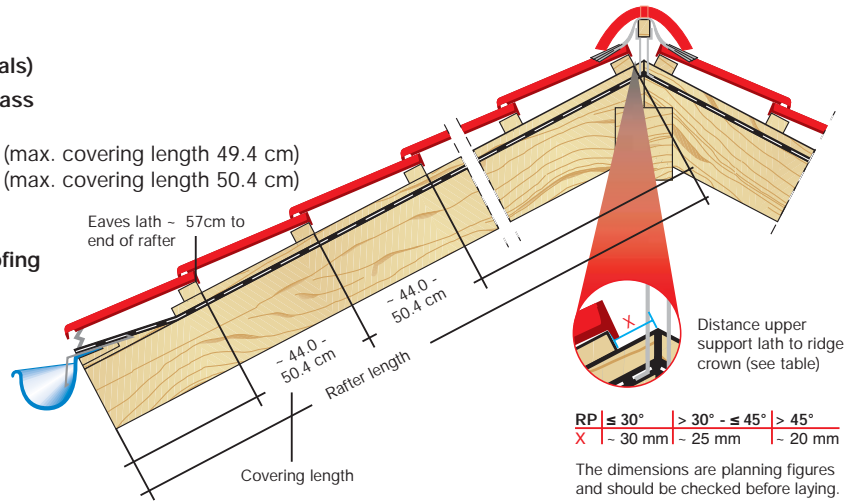

Details eaves design

The dimensions are planning figures and should be checked before laying depending on the design and local circumstances.

1 With gutter & vent element

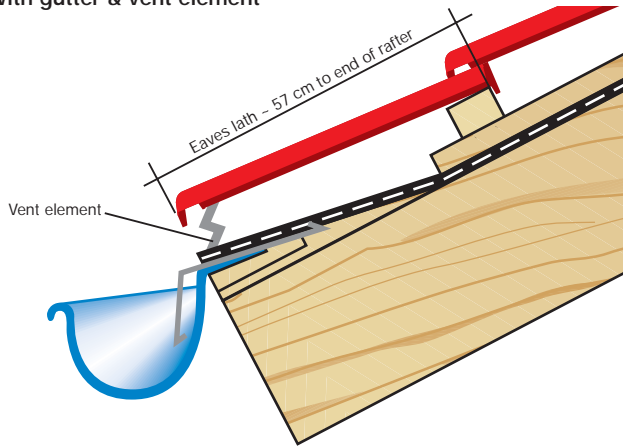

2 High-level gutter (recommended for flat roof pitches < 22°)

Tile overhang in gutter
max. 1/3 of gutter width

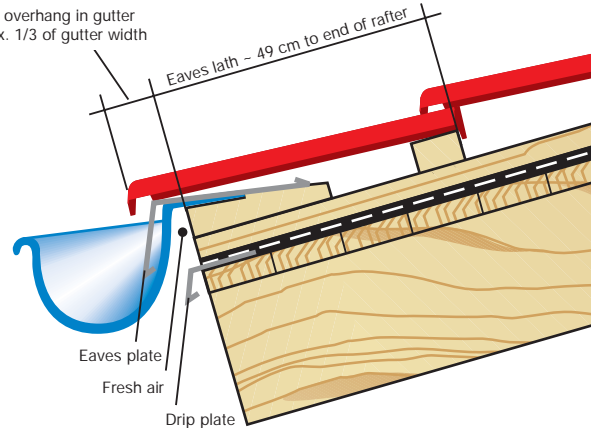

Ridge/crest details

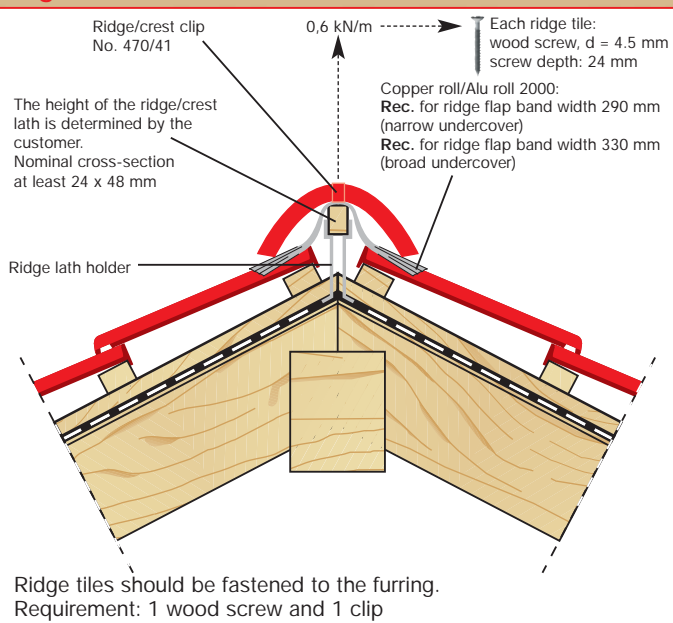

Verge details

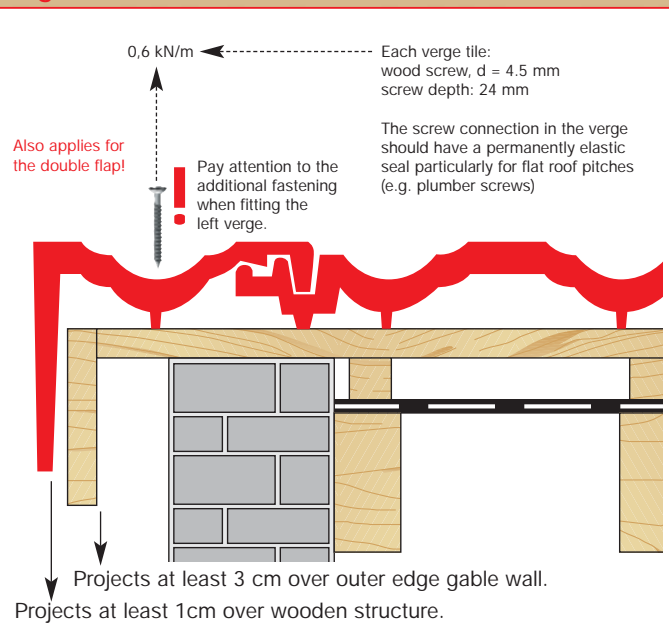

Additional fastening principle for left verge

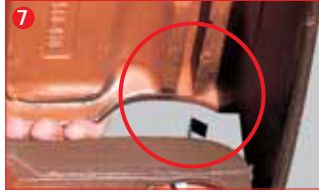

- 1 Included with every left verge tile: clip, SX 5 plug and Phillips screw VA 3.5 x 25 mm (ready assembled); wood screw VA 4.5 x 45 mm to fasten the verge.
- 2 As usual, fasten the verge tile with the VA 4.5 x 45 mm screw at least 24 mm into the lath.
- 3 The pre-assembled new fastening (clip, plug, Phillips screw) should be fastened to the head of the verge.
- 4 Fasten fingertight.
- 5 The verge tiles have a special slit on their underside.
- 6 When laying the overlapping verge tiles press firmly into place until the clips are heard to catch in this slit.
- 7 During further installation of the verge tile proceed as described above.

Installation instructions for alu base tile with single step/walking grid tile/snow stop tile

Of stainless steel/aluminium. No supporting laths needed!
Fastening to supporting lath: Aluminium tile fastened to lath with 2 screws (V2A screw included)

Processing acc. to DIN 18160-5

Article	≤ 45°	> 45°
Walking grid tile	every row of tiles	every row of tiles
Alu base tile	every row of tiles	every row of tiles
w step tile	every row of tiles	every row of tiles

tested to DIN EN 516

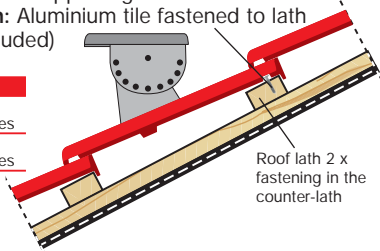

The same applies for alu pantiles with snow rib or round wood holder, whereby the max. support spacing should not exceed 90 cm. For higher demands you should reduce the support spacing (60 cm).

Clear spacing of laths

If using large area clay roof tiles a **clear** lath spacing of ≤ 0.4 m (rounded off up to and including 44.4 cm) is allowed. This is confirmed by the „Trade Association Technical Committee on Building“.

• See **Technical Rules of the German Roofing Trade, notes on wood and timber materials**

- According to the BG Rules "Roofing work" (BGR 203) or "Carpentry and wood work" (BGR 214), roof areas with that have roof lath intervals with a clear span of ≤ 0.4 m are regarded as closed roof areas.

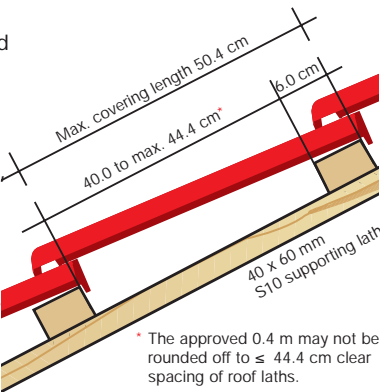

Shed roof tile

Shed roof tiles should be fastened to the furring (see detail verge).

Size sheets can be downloaded from the Internet or on the data service CD

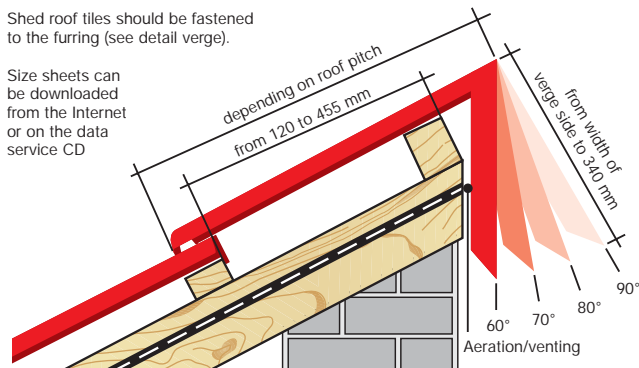

- 90° • lath size of ~ 120 - 455 mm
- 80° = RP 10° • lath size of ~ 120 - 445 mm
- 70° = RP 20° • lath size of ~ 120 - 415 mm
- 60° = RP 30° • lath size of ~ 120 - 395 mm

Aeration and ventilation in steep roof

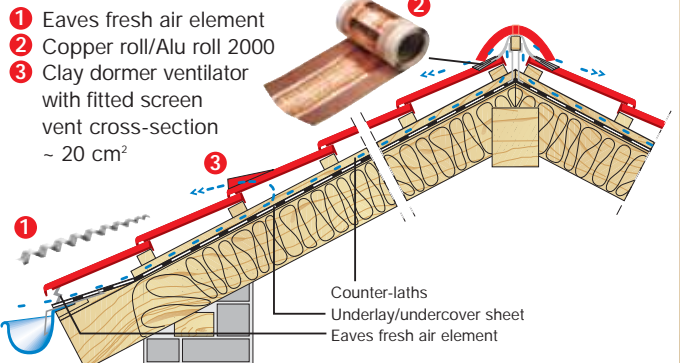

- 1) The vent cross-section at the eaves should be at least 200 cm²/m of eaves.
- 2) The vent cross-section at the ridge or crest should be at least 0.5‰ of the total corresponding roof area, though at least 50 cm². (according to DIN 4108-3)

Multi storm claw



That's new:
Maximum protection against wind suction and easy installation:

The multi storm claw is placed on top of the gutter tile at the appropriate point and screwed to the laths. The roof tiles remain **completely free of screw holes that could impair their function**. There is a clay groove pressed into the underside of the tile where the multi storm claw can be clipped into place. After screwing into place the next overlapping tile is simply laid in position. The multi storm claw audibly clips/grips the clay groove after a slight pressure is exerted on the tile.

The multi storm claw ensures a combined (2-fold) fastening of the roof tile at its top and bottom.

The pull-out values of former common side rabbit clips are greatly exceeded. The tiles are fastened in place absolutely stormproof in accordance with the technical rules for roofing.

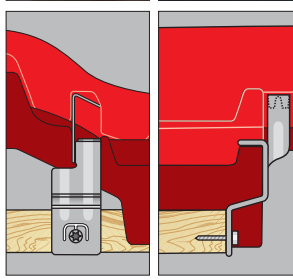

On the NELSKAMP data service CD or as a download on the Internet from www.nelskamp.de

- Product specifications
- Laying instructions
- CAD data

DOWNLOAD



For colourful, clean roofs. The Nelskamp concrete roofing tile program.



CLIMALIFE concrete roofing tiles

With their ClimaLife surface our roof pantiles clean our environment from contaminants resulting from heating, traffic and the industry. Up to 90 percent are neutralized in daylight, without sunlight up to 70 percent. This is due to the titanium oxide content in the micro concrete. It mainly converts nitrogen oxides (NO_x) into harmless substances like NO₃⁻. Again and again, because titanium oxide is a catalyst, which is never used up. The rain does the rest: It just flushes away the substances, which then are harmless.

LONGLIFE concrete roofing tiles

The leading technology of LONGLIFE concrete roofing tiles is based on the smooth surface of micro-concrete and a newly developed, silk-gloss colour coating. Both factors ensure clean roofs with long-lasting, intensive colours. The reason: dirt is washed off by rain and moss or algae find almost no base for growth.

SELF-CLEANING (SG) concrete roofing tiles

SG = Self-cleaninG concrete roofing tiles are also supplied with the newly developed colour coating. Moss and algae find almost no base for growth on the surface.

TOP 2000 S concrete roofing tiles

High-quality raw materials, the latest production methods and established coating technologies with numerous standard and special colours are characteristic of TOP 2000 S concrete roofing tiles.



Concrete roofing tiles and clay roof tiles from Nelskamp. The obvious solution.

Our strategically placed production facilities guarantee that our roof building materials are always well received. Six plants throughout Germany are the sound, logistical basis for co-operation and help spare the environment.

Administration and sales

Waldweg 6 · D-46514 Schermbeck
Postfach 11 20 · D-46510 Schermbeck
Phone: +49 28 53/91 30-0
Fax: +49 28 53/37 59
Email: vertrieb@nelskamp.de
Internet: www.nelskamp.de

Production of concrete roofing tiles

Gartrop Works
Gahlener Straße 158
D-46569 Hünxe-Gartrop
Phone: +49 28 53/91 30-31/32
Fax: +49 28 53/45 59

Dieburg Works
Lagerstraße 30
D-64807 Dieburg
Phone: +49 60 71/98 64-0
Fax: +49 60 71/16 73

Schönerlinde Works
Schönerlinder Bahnhofstraße 6
D-16348 Wandlitz
Phone: +49 30/94 03 91-0
Fax: +49 30/94 12 20 4

Production of clay roof tiles

Schermbeck Works
Waldweg 6
D-46514 Schermbeck
Phone: +49 28 53/91 30-23/17
Fax: +49 28 53/26 70

Unsleben Works
Wechterswinkler Straße 23
D-97618 Unsleben
Phone: +49 97 73/9 10 10
Fax: +49 97 73/7 49

Groß-Ammensleben Works
Magdeburger Straße 42
D-39326 Groß-Ammensleben
Phone: +49 3 92 02/88-6
Fax: +49 3 92 02/88 80 2

From clay. From concrete. From experience.

NELSKAMP