

Technical data

Roofing tile	S pantile
Manufacturer	Nelskamp (D)
Overall length	~ 42.0 cm
Overlap	~ 7.5 - 10.6 cm (depending on roof pitch)
Overall width	~ 33.2 cm
Covering width	~ 30.0 cm
Covering length	~ 31.4 - 34.5 cm (depending on roof pitch)
Requirement per m ²	~ 10.0 pieces
Weight per tile	~ 4.7 kg
Weight per m ²	~ 47.0 kg
Regular roof pitch	22°



Available with the surfaces CLIMALIFE, LONGLIFE and SELF-CLEANING (SG)

tile red, dark brown, black, slate grey, moss green, blue, granite, new red, autumn colours, red, brown, cement-grey

Laying!

The following applies for laying our concrete roofing tiles:

1. The NELSKAMP manufacturer's instructions take priority (laying instructions)
2. The specialist rules of the roofing trade (rules for coverings with concrete roofing tiles)
3. The Construction Contract Procedures VOB (concrete roofing tiles)

Material requirements for coverage

Laths	~ 3.3 m/m ² (incl. 10% waste)
Counter-laths	~ 1.7 m/m ² (incl. 10% waste)
Roofing tiles	~ 10.0 pieces/m ²
Packing unit*	
Pantiles per stack	34 pieces (packed on pallets on request: 204 pieces per Europallet)
Half tile	as required, ~ 3.0 pcs/m
Double flap	~ 3.0 pieces/m for left side of roof only
Gable tiles for counter-laths	~ 3.0 pieces/m
Step tile with support clip	as required
Step tile with single step	as required
Ridge or crest tile	~ 2.5 pieces/m
Copper roll/Alu roll 2000 (5 m per roll)	as required
Ridge or crest clip 470/77	1.0 piece per ridge tile
Wood screws	1.0 piece per ridge tile d = 4.5 mm Screw depth 24 mm
Ridge or crest disc	1.0 piece per ridge or crest end
Ridge lath holder	1.0 piece per rafter
Crest lath holder	1.0 piece/ ~ 70 cm
Eaves fresh air element	~ 1.1 piece/m Fresh air ~ 200 cm ² /m

* only applies for deliveries in Germany

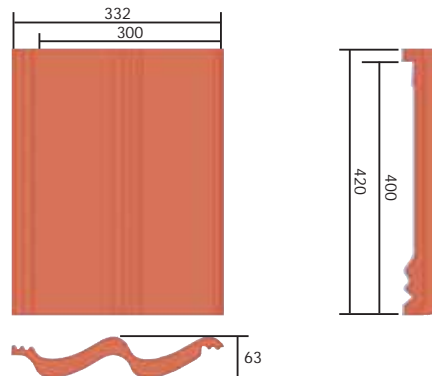

Storm clips

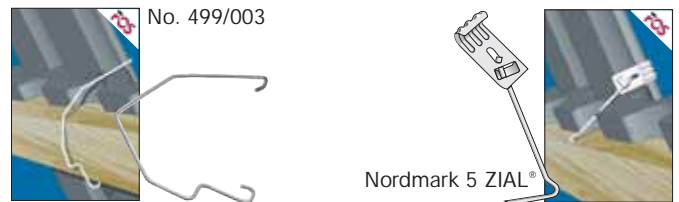

According to professional standards, we can supply storm clips for a simple and effective protection against wind suction. They can alternatively be clipped to the laths or knocked into the laths. Resistant to corrosion through stainless steel wire 1.4301 (A2) or ZIAL® coating (corrosion protection).

Covering widths

Gable tile for counter-laths

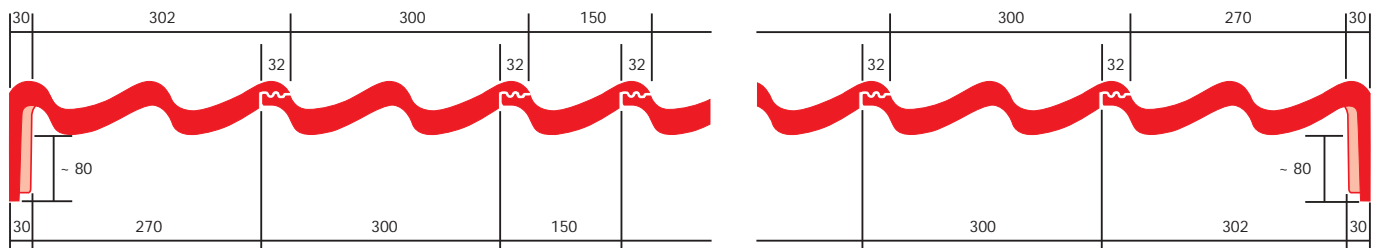

covering width left gable tile = 30.2 cm
covering width double flap tile = 33.2 cm

covering width right gable tile = 27.0 cm

Classification of additional measures except for subordinate buildings ¹⁾ according to the technical rules of the German roofing trade, last revised January 2010

Roof pitch	Higher requirements ²⁾			
	Use - Design - Climatic conditions			
	no further increased requirement ²⁾	one further increased requirement ²⁾	two further increased requirement ²⁾	three further increased requirement ²⁾
≥ 22°	Class 6 3.3 Underlayment (USB- A) ⁴⁾	Class 6 3.3 Underlayment (USB- A) ⁴⁾	Class 5 2.4 Overlapping / interlocking undercover (UDB- A; UDB- B ⁵⁾ ; USB- A) ⁴⁾	Class 4 2.2 Welded / bonded undercover 2.3 Undercover covered with bitumen sheeting 3.2 Underlayment secured at seams (UDB- A; UDB- B ⁵⁾ ; USB- A) ⁴⁾
≥ 18°	Class 4 2.2 Welded / bonded undercover 2.3 Undercover covered with bitumen sheeting 3.2 Underlayment secured at seams (UDB- A; UDB- B ⁵⁾ ; USB- A) ⁴⁾	Class 4 2.2 Welded / bonded undercover 2.3 Undercover covered with bitumen sheeting 3.2 Underlayment secured at seams (UDB- A; UDB- B ⁵⁾ ; USB- A) ⁴⁾	Class 3 2.1 Undercover secured at seams and perforations 3.1 Underlayment secured at seams and perforations (UDB- A; UDB- B ⁵⁾ ; USB- A) ⁴⁾	Class 3 2.1 Undercover secured at seams and perforations 3.1 Underlayment secured at seams and perforations (UDB- A; UDB- B ⁵⁾ ; USB- A) ⁴⁾
≥ 14°	Class 3 2.1 Undercover secured at seams and perforations 3.1 Underlayment secured at seams and perforations (UDB- A; UDB- B ⁵⁾ ; USB- A) ⁴⁾	Class 3 2.1 Undercover secured at seams and perforations 3.1 Underlayment secured at seams and perforations (UDB- A; UDB- B ⁵⁾ ; USB- A) ⁴⁾	Class 3 2.1 Undercover secured at seams and perforations 3.1 Underlayment secured at seams and perforations (UDB- A; UDB- B ⁵⁾ ; USB- A) ⁴⁾	Class 3 ³⁾ 2.1 Undercover secured at seams and perforations 3.1 Underlayment secured at seams and perforations (UDB- A; UDB- B ⁵⁾ ; USB- A) ⁴⁾
≥ 10°	Class 2 1.2 Rainproof roof substructure	Class 2 1.2 Rainproof roof substructure	Class 1 1.1 Waterproof roof substructure	Class 1 1.1 Waterproof roof substructure
MRP			10°	

- 1) The additional measures named in the table are minimum measures taking into account table 1 of the "Leaflet for roof substructures, undercovers, underlays".
- 2) Higher requirements form categories in accordance with Section 1.1.3. Further higher requirements may result from the weighting within a category according to Section 1.1.3. For example, climatic conditions can lead to several higher requirements.
- 3) Only allowed if proof has been rendered of the functional reliability of the products used including accessories (sealing tapes, adhesive tapes, sealing compounds, ready-made seam protection, etc.) by the manufacturer during a driving rain test. The next highest class should otherwise be chosen.
- 4) Undercover plates are to be assigned according to the classification in the "Leaflet for roof substructures, undercovers and underlays".
- 5) If indices 2), 3), 4), 5) in the product data sheet are met:
 - 2) Resistance to driving rain, proven by the "Driving rain test underlay and undercover sheets - TU Berlin"
 - 3) Higher requirements on ageing are proven by increasing the temperature in the test method Appendix C 5.2 of DIN EN 13859- 1 to 80 °C.
 - 4) The manufacturer specifies the duration of the outdoor weathering period whilst warranting the aforementioned properties.
 - 5) The manufacturer confirms the suitability as a provisional cover and specifies the duration of the outdoor weathering period whilst warranting the aforementioned properties.

Roof lathing in conjunction with ridge flaps (dry ridge)

Supporting laths:

The following min. cross-sections must be used:
(rules for roofing, notes on wood and timber materials)

Nom. cross-sections of support laths	Rafter intervals (unit spacing)	Sizing class
30 x 50 mm	≤ 80 cm	S 10
40 x 60 mm	≤ 100 cm	S 10

Counter-laths:

Rec. thickness of counter-laths acc. to rules for roofing
(notes on wood and timber materials):

Rafter length	Rec. thickness
up to 8 m	24 mm
up to 12 m	30 mm
over 12 m	40 mm

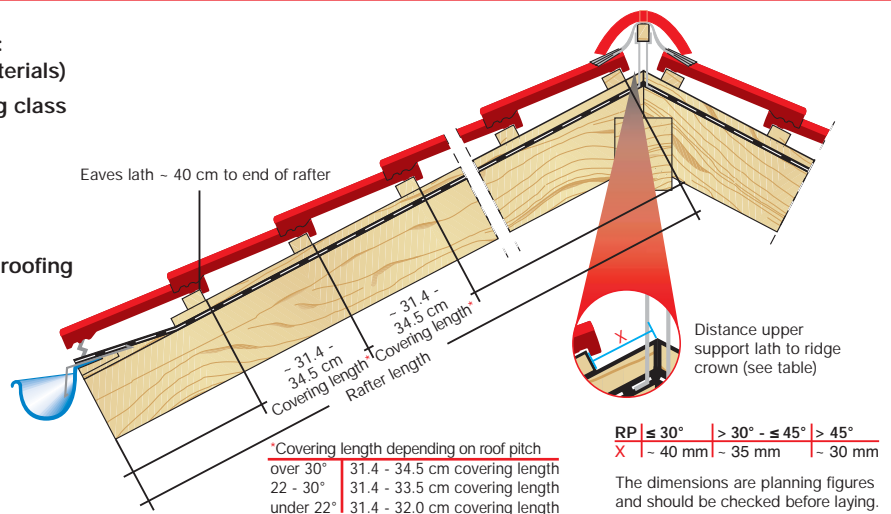

Details eaves design

The dimensions are planning figures and should be checked before laying depending on the design and local circumstances.

1 With gutter & vent element

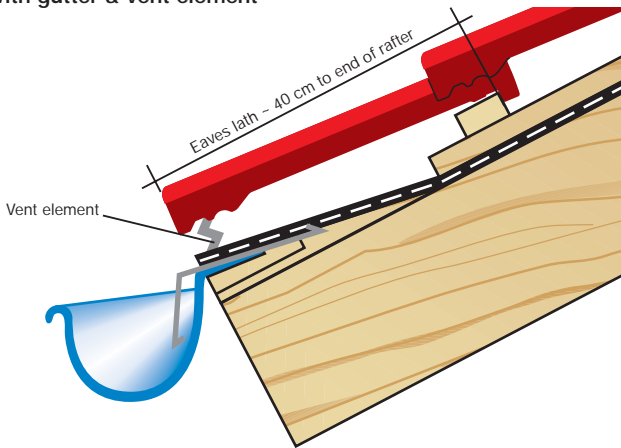

2 High-level gutter (recommended for flat roof pitches < 22°)

Pantile overhang in gutter max. 1/3 of gutter width

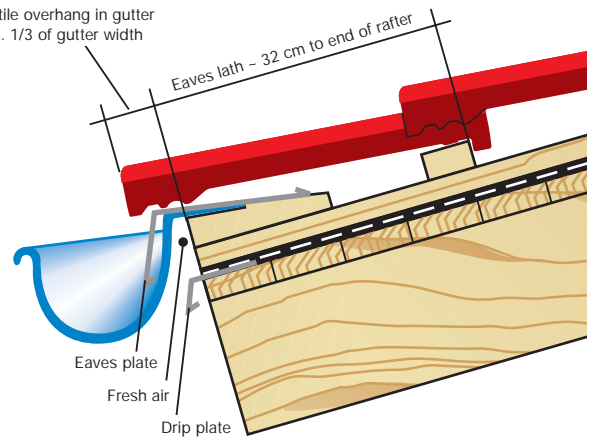

Ridge/crest details

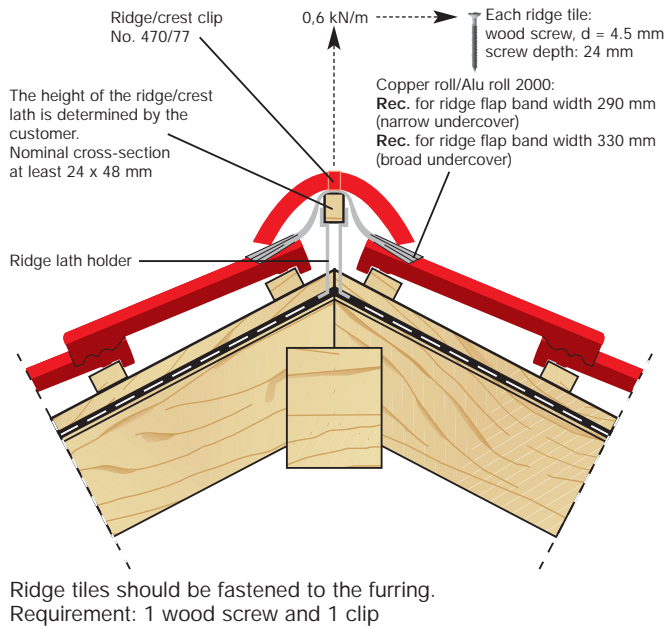

Gable tile details

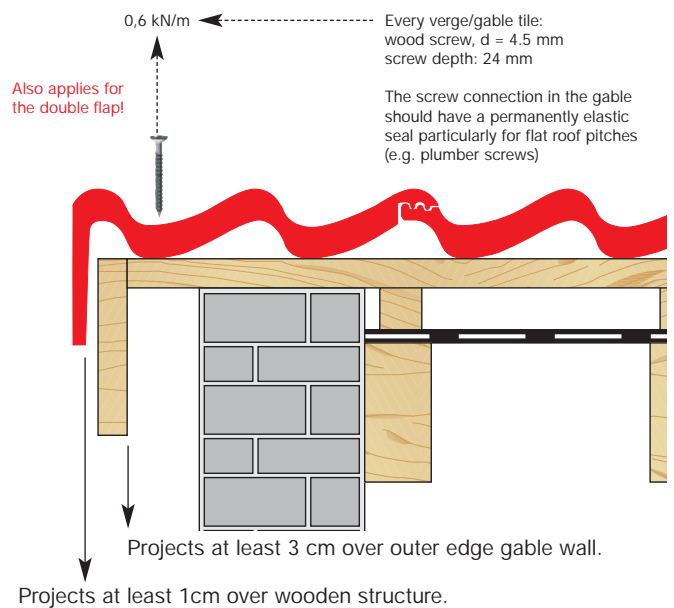

Installation instruction for step tiles with single step/walking grid/snow stop tile

Every step tile must be provided with an additional supporting-safety lath (same lath cross-section as for the supporting laths).

Fastening to supporting lath: Two corrosion-proof wood screws (4.5 x 45 mm per step tile)

Processing acc. to DIN 18160-5

Article	≤ 45°	> 45°
Step tile	every 2 nd row of walking grid	every row of roofing tiles
Step tile	every row of roofing tiles	every row of roofing tiles
Single step	every row of roofing tiles	every row of roofing tiles

tested to DIN EN 516

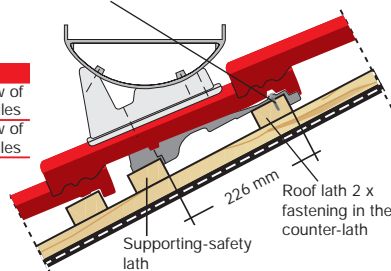

The same applies for metal roof plates with snow ribs or round wood holder, whereby the max. support spacing should not exceed 90 cm. For higher demands you should reduce the support spacing (60 cm).

Fore-part gable tile

11 cm for covering length 31.4 - < 33.3 cm
 9 cm for covering length ≥ 33.3 - 34.5 cm

Mansard and pent roof tile

A + B max. 450 mm

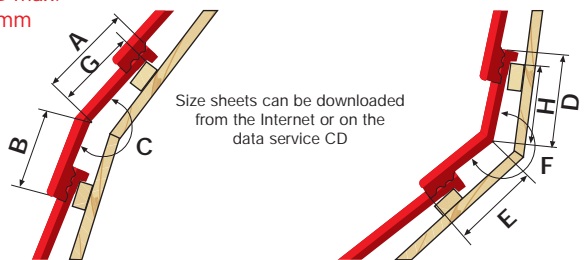

Shed roof tile

Shed roof tile for counter-laths	
A	42.0 cm
B	12.0 cm
C	37.0 cm
D	1.8 cm

With 90° shed roofs
Lath size: size C
minus height overlap
(7.5 – 10.0 cm)

Screw hole
ø 8 mm

Shed roof tiles should be fastened to the furring (see details of gable tile).

Size sheets can be downloaded from the Internet or on the data service CD

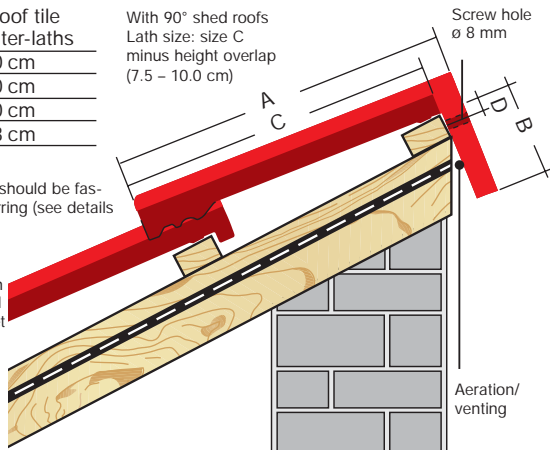

Aeration and ventilation in steep roof

- 1 Eaves fresh air element
- 2 Copper roll/Alu roll 2000
- 3 Clay dormer ventilator with fitted screen
vent cross-section
~ 27 cm²

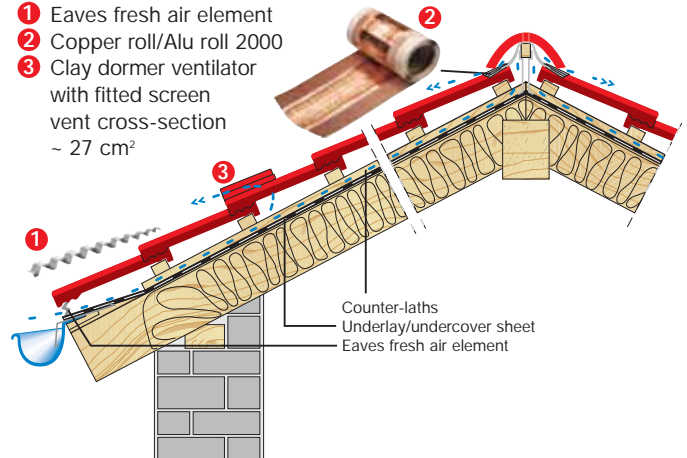

- 1) The vent cross-section at the eaves should be at least 200 cm²/m of eaves.
- 2) The vent cross-section at the ridge or crest should be at least 0.5‰ of the total corresponding roof area, though at least 50 cm².
(according to DIN 4108-3)